

KLIK KLIK WORKBOOK

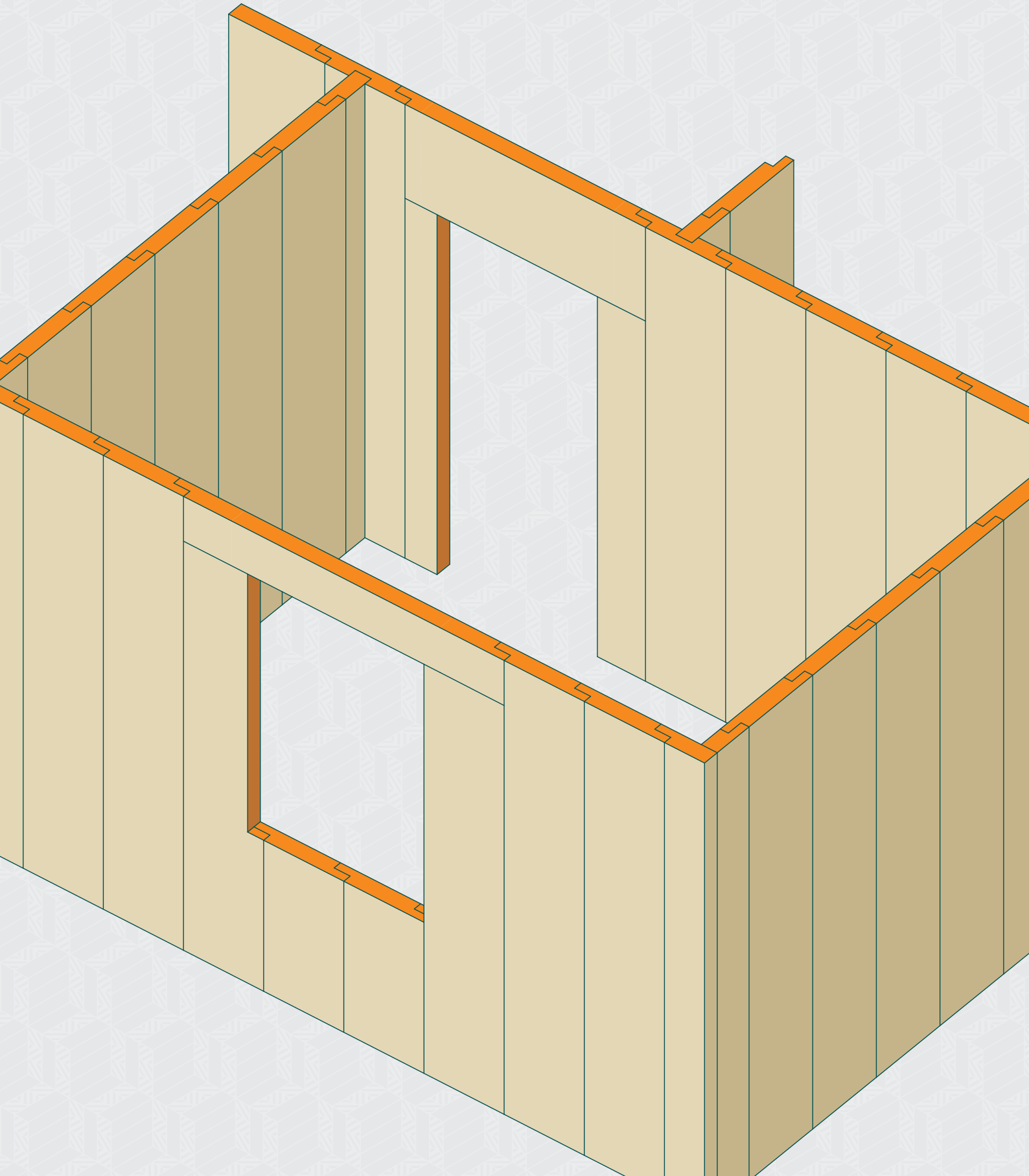

Types of KLIK-KLIK™ panels

1

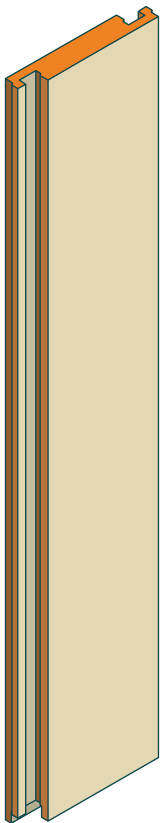

CLT-01

Covering size:
50 x 290 x 10

Overall size:
61 x 290 x 10

Weight:
65.5kg

Usage:
externalwalls/internalwalls

2

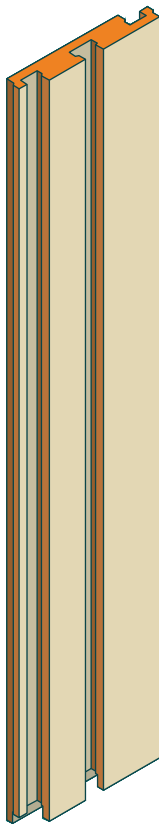

CLT-02

Covering size:
50 x 290 x 10

Overall size:
61 x 290 x 10

Weight:
56.5kg

Usage:
externalwalls/internalwalls

3



CLT-03

Covering size:
24.5 x 290 x 10

Overall size:
32 x 290 x 10

Weight:
31.5kg

Usage:
externalwalls/internalwalls

4

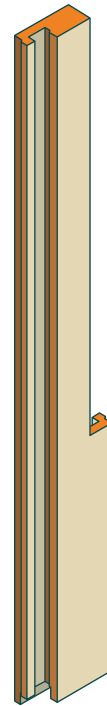

CLT-04

Covering size:
25 x 260 x 10

Overall size:
36 x 260 x 10

Weight:
27kg

Usage:
externalwalls/internalwalls

5

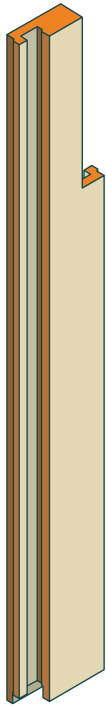

CLT-05

Covering size:
25 x 260 x 10

Overall size:
36 x 260 x 10

Weight:
28.5kg

Usage:
externalwalls/internalwalls

6

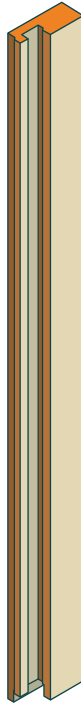

CLT-06

Covering size:
15 x 260 x 10

Overall size:
25 x 260 x 10

Weight:
25kg

Usage:
externalwalls/internalwalls

7

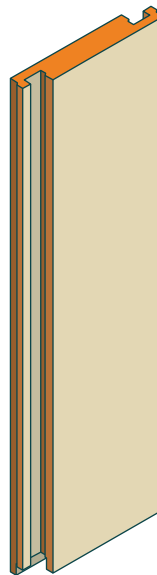

CLT-07

Covering size:
50 x 193 x 10

Overall size:
61 x 193 x 10

Weight:
44kg

Usage:
externalwalls/internalwalls

8

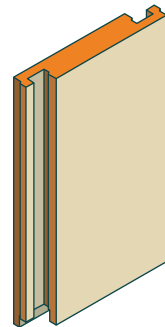

CLT-08

Covering size:
50 x 96.5 x 10

Overall size:
61 x 96.5 x 10

Weight:
22kg

Usage:
externalwalls/internalwalls

9

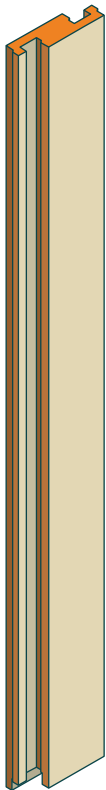

CLT-09

Covering size:
25.5 x 290 x 10

Overall size:
35.5 x 290 x 10

Weight:
27kg

Usage:
externalwalls/internalwalls

10

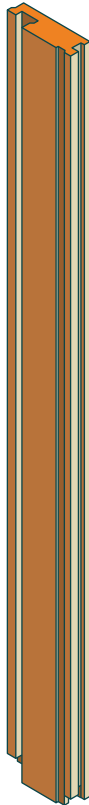

CLT-10

Covering size:
15.5 x 290 x 10

Overall size:
32 x 290 x 10

Weight:
27kg

Usage:
externalwalls/internalwalls

11

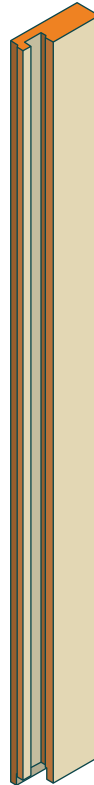

CLT-11

Covering size:
19.5 x 290 x 10

Overall size:
30.5 x 290 x 10

Weight:
25kg

Usage:
externalwalls/internalwalls

12

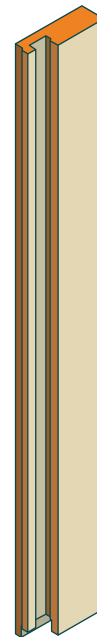

CLT-12

Covering size:
20.5 x 230 x 10

Overall size:
30.5 x 230 x 10

Weight:
23kg

Usage:
externalwalls/internalwalls

13

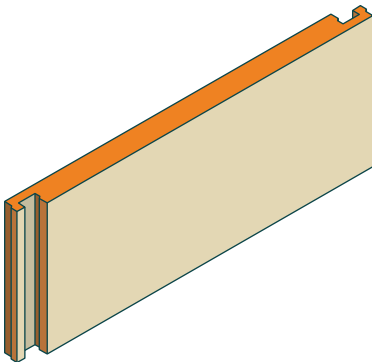

CLT-13

Covering size:
150 x 60 x 10

Overall size:
161 x 60 x 10

Weight:
41kg

Usage:
externalwalls/internalwalls

15

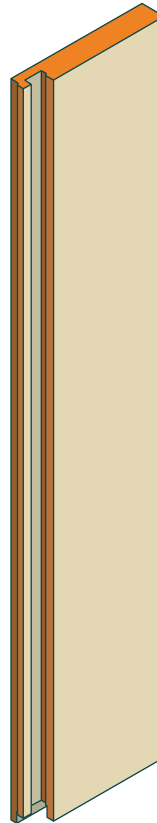

CLT-15

Covering size:
51 x 290 x 10

Overall size:
61 x 290 x 10

Weight:
72.5kg

Usage:
externalwalls/internalwalls

16

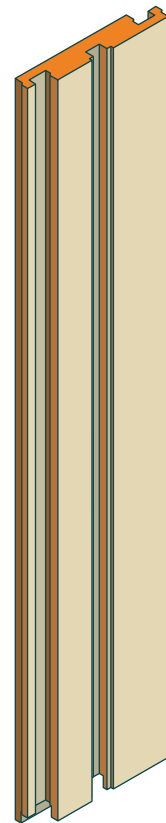

CLT-16

Covering size:
51 x 290 x 10

Overall size:
61 x 290 x 10

Weight:
65.5kg

Usage:
internalwalls

14

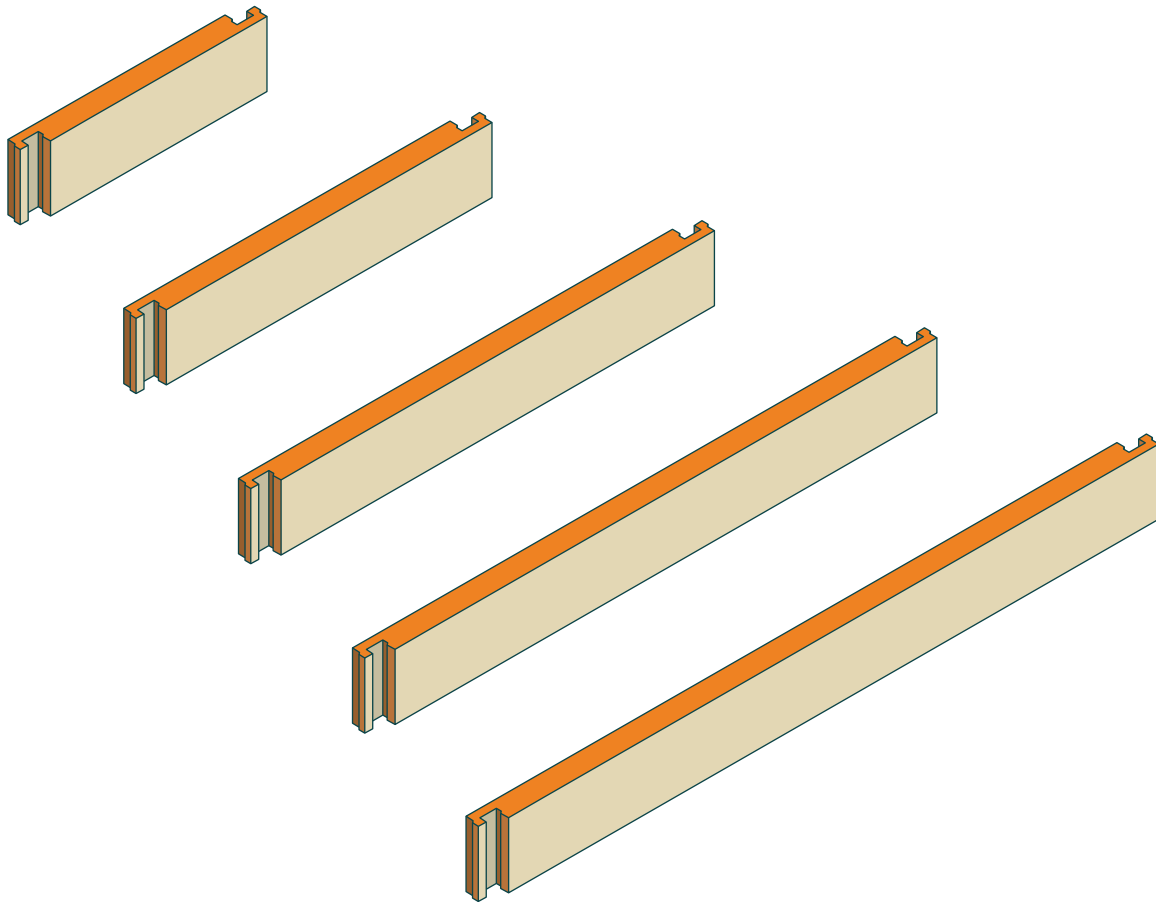

GL-14-1

Covering size:
100 x 30 x 10

Overall size:
111 x 30 x 10

Weight:
15kg

Usage:
externalwalls/internalwalls

GL-14-2

Covering size:
161 x 30 x 10

Overall size:
150 x 30 x 10

Weight:
21kg

Usage:
externalwalls/internalwalls

GL-14-3

Covering size:
200 x 30 x 10

Overall size:
211 x 30 x 10

Weight:
27.5kg

Usage:
externalwalls/internalwalls

GL-14-4

Covering size:
250 x 30 x 10

Overall size:
251 x 30 x 10

Weight:
32kg

Usage:
externalwalls/internalwalls

GL-14-5

Covering size:
300 x 30 x 10

Overall size:
311 x 30 x 10

Weight:
38.5kg

Usage:
externalwalls/internalwalls

KLIK KLIK™

Basic assembly scheme
for each element type

Window block

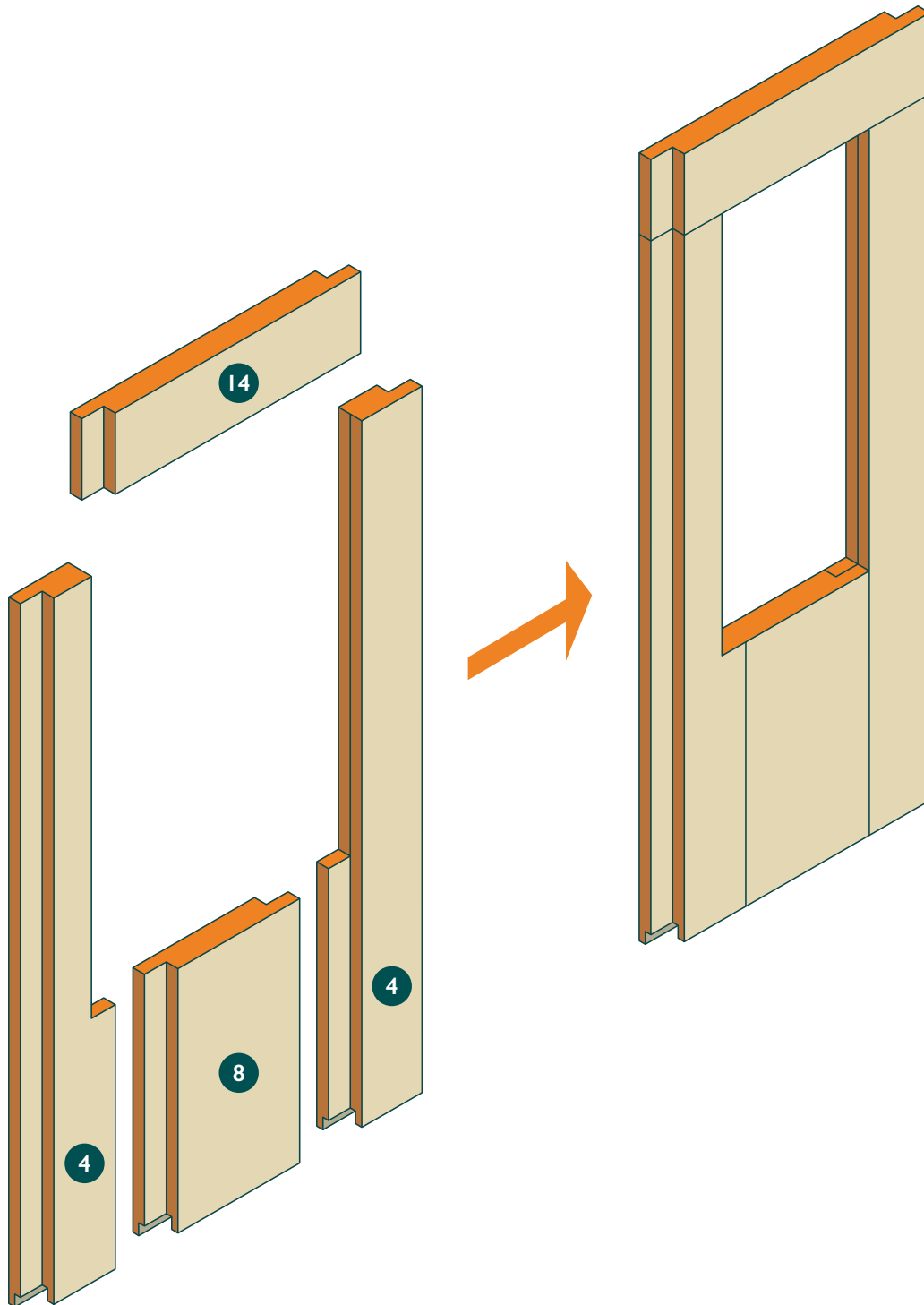

Window block

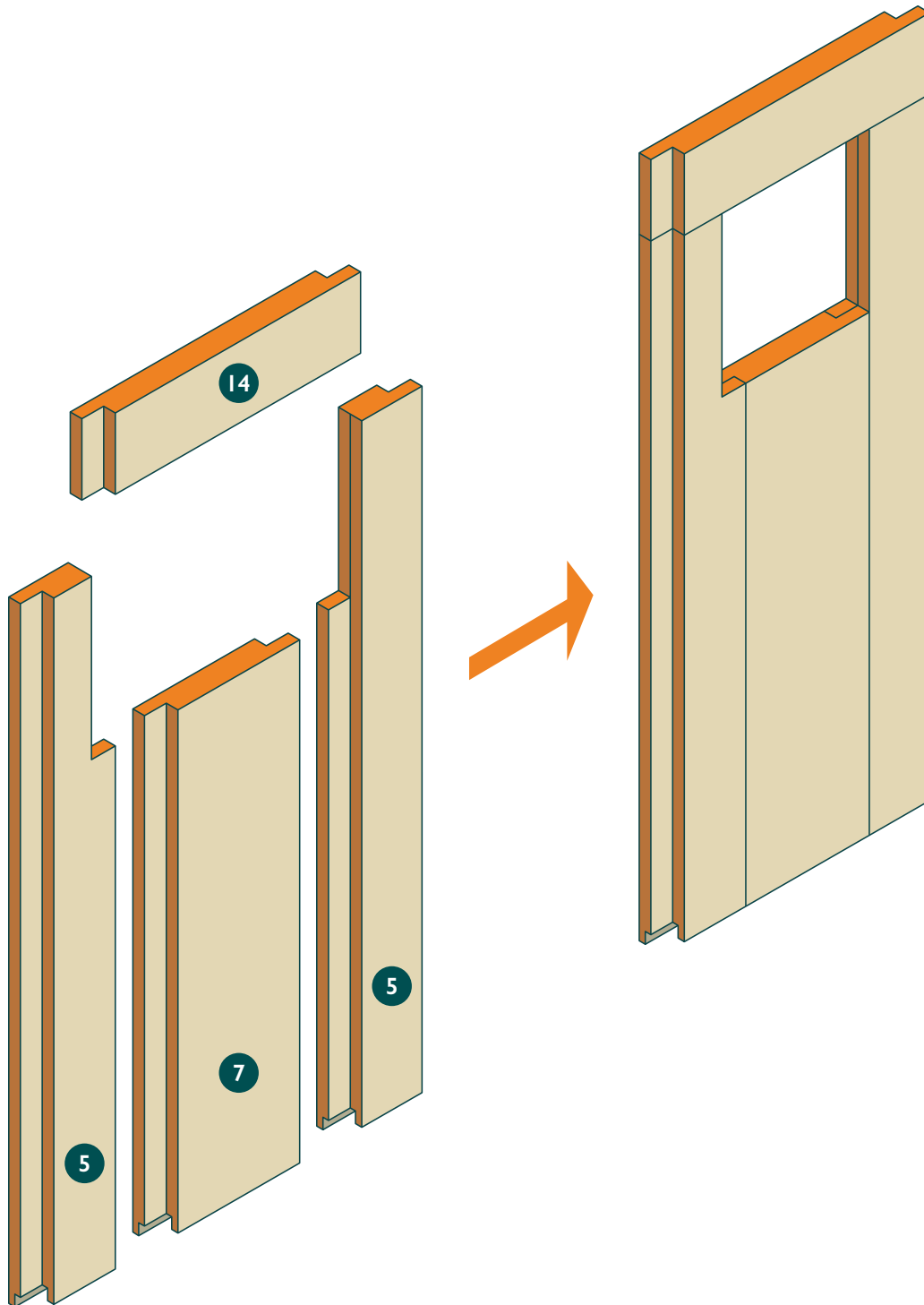

Window block

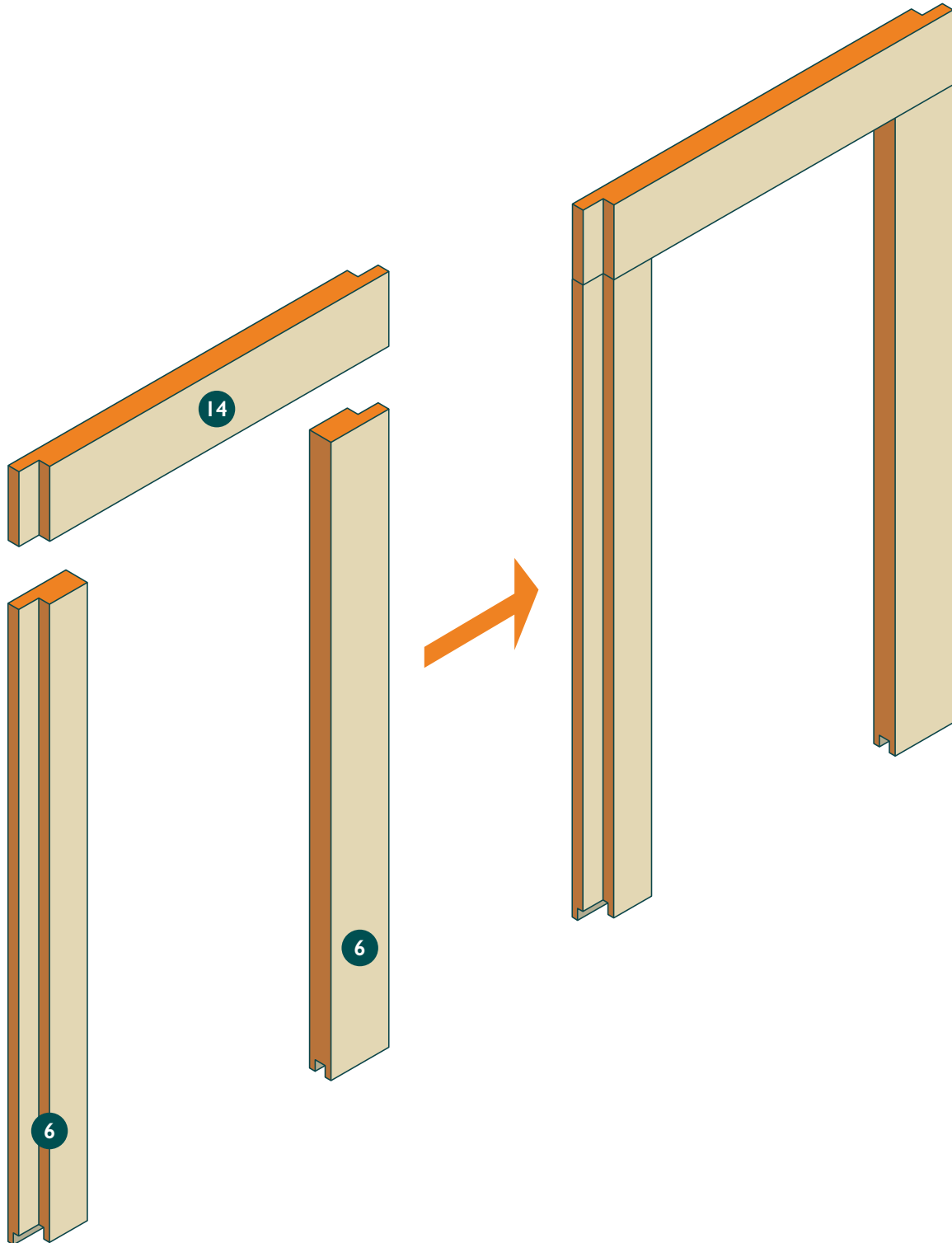

Door block

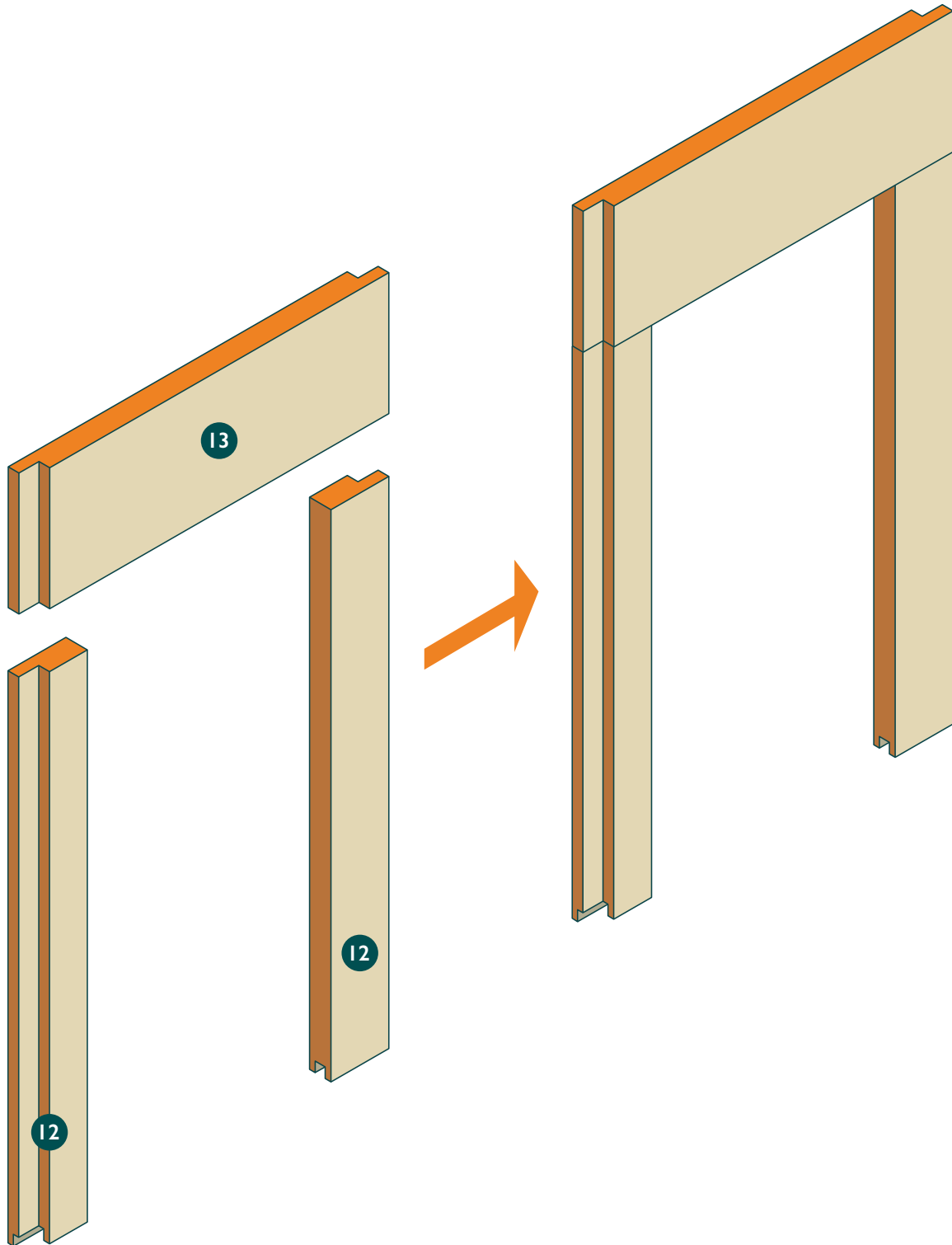

Partition wall connection

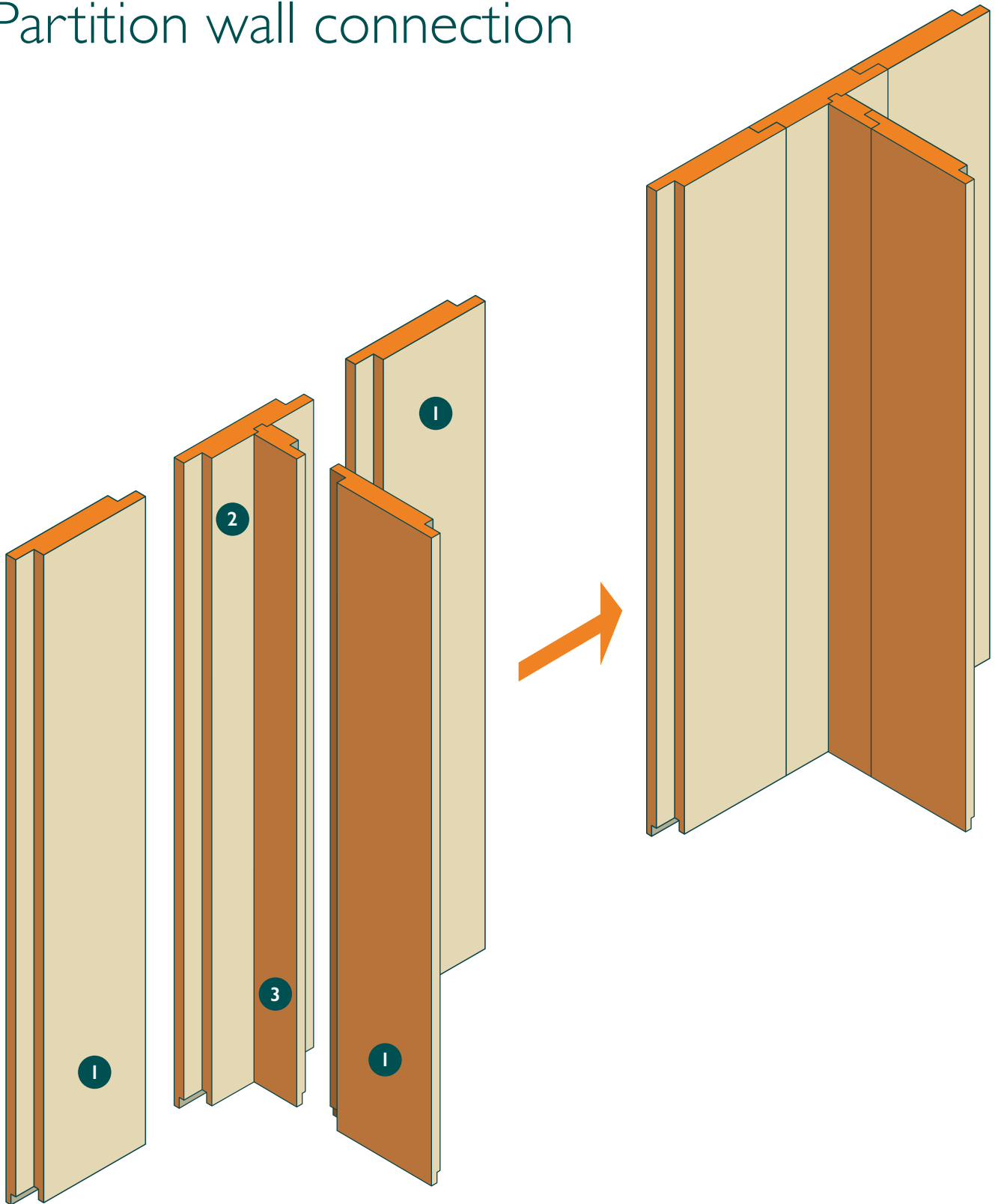

Partition wall end - narrow elements

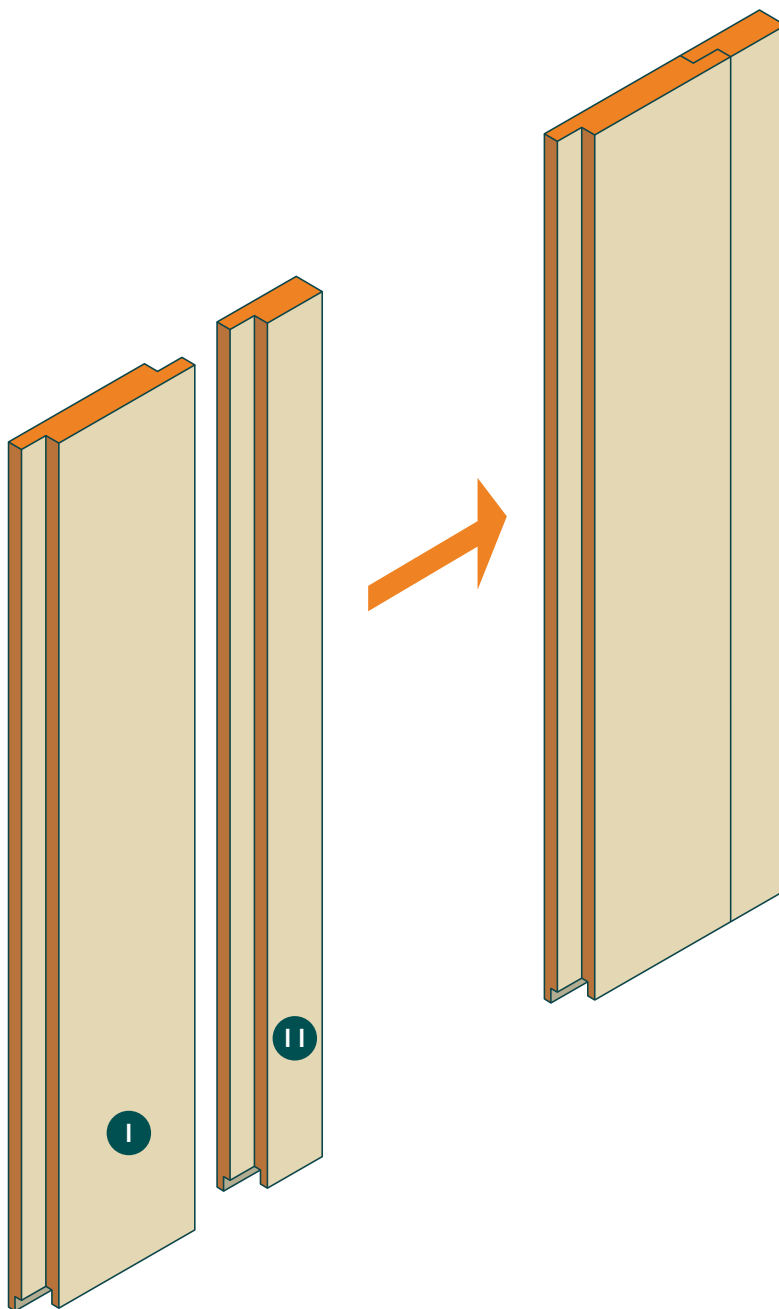

Partition wall end - wide elements

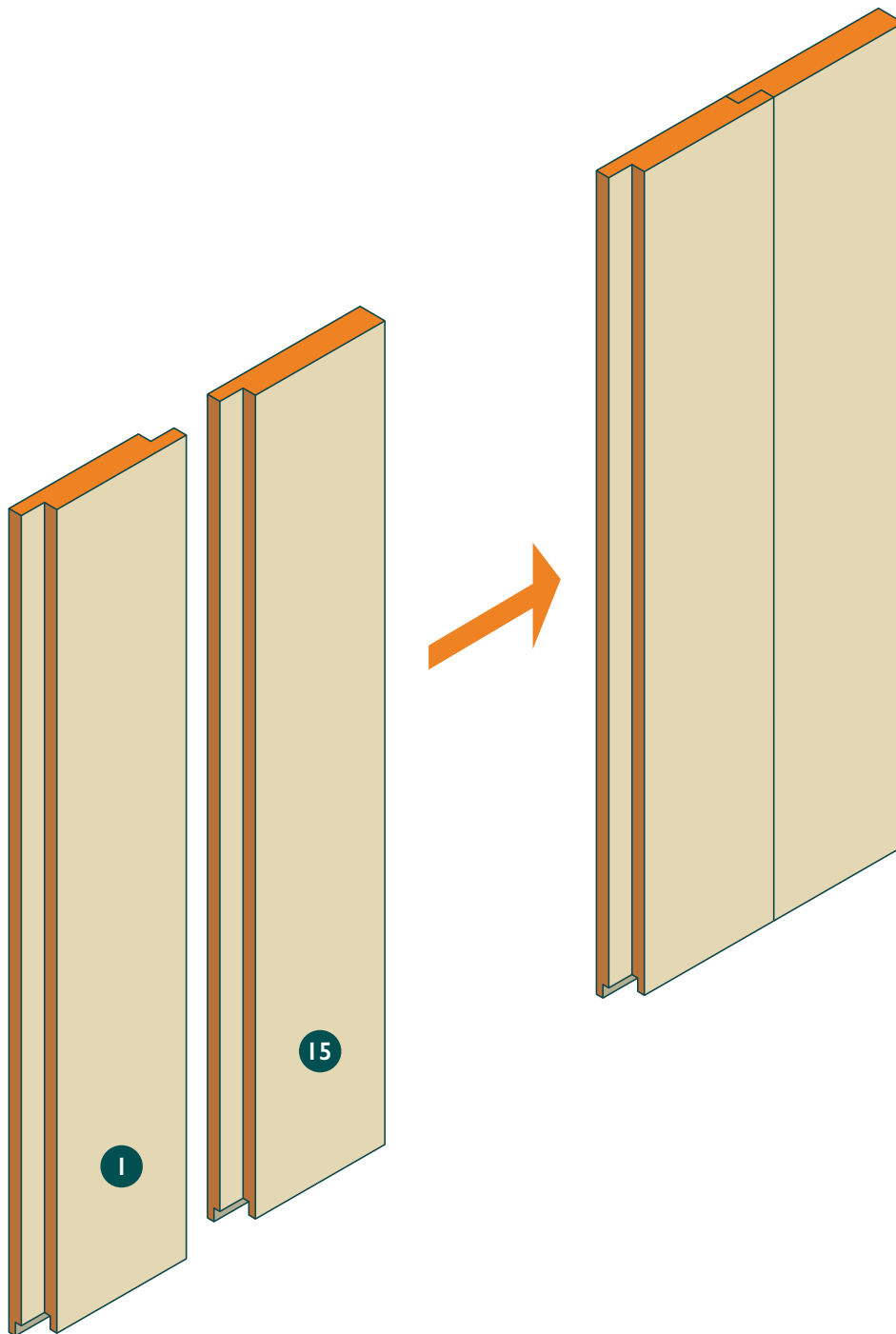

KLIK KLIK™

Panel wall assembly
from foundations to walls

Foundation batten assembly

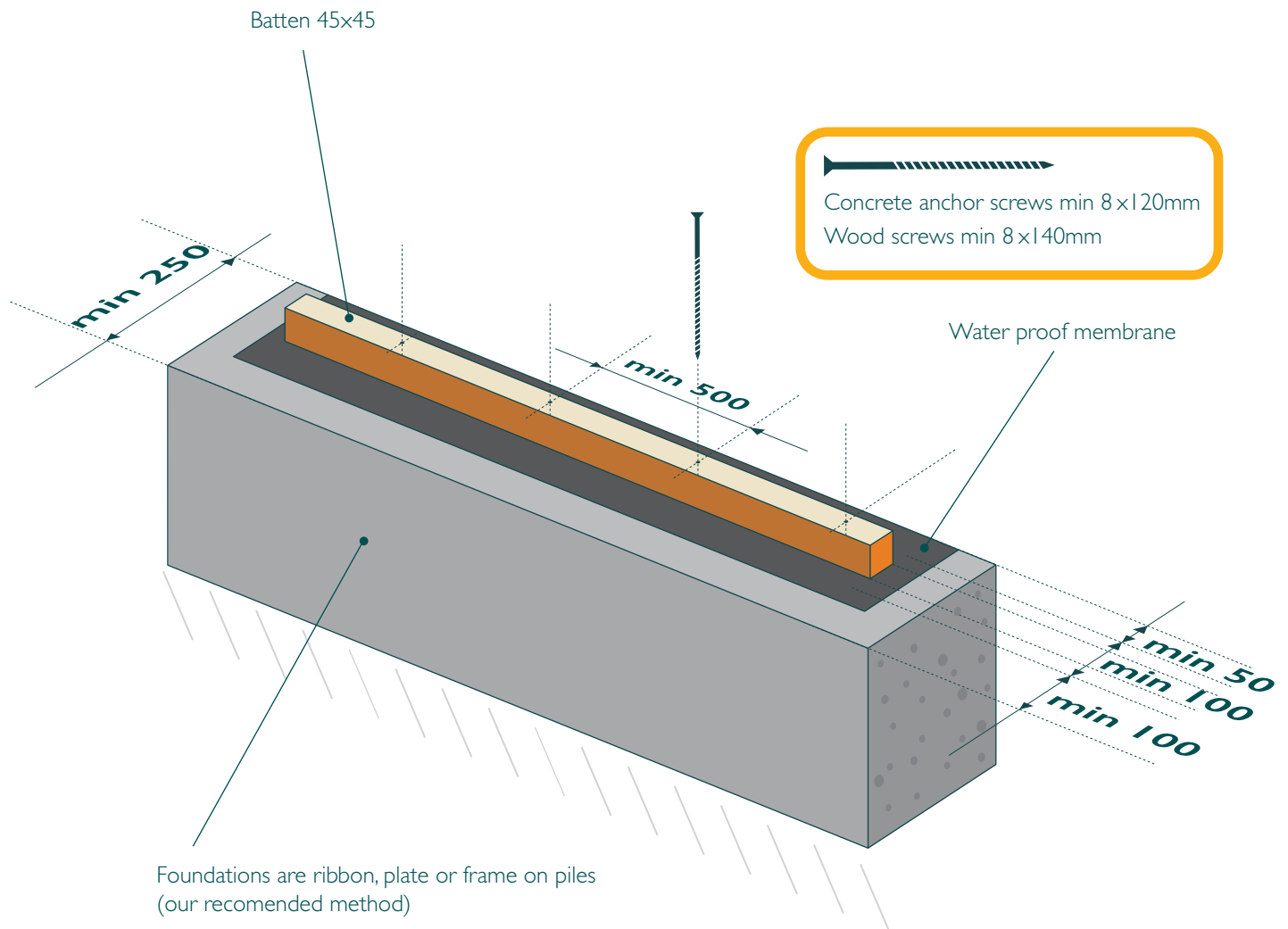

1. Foundations - they can be ribbon, slab, or a frame on piles (our recommended method)
2. Batten size 45x45 mm
3. Necessary screw distance of batten assembly min 500 mm
4. Necessary screw size - for concrete 8x120 mm, for wood – min 8x140 mm

!!! Assembly of the structure only according to the engineering project

Starting the panel assembly

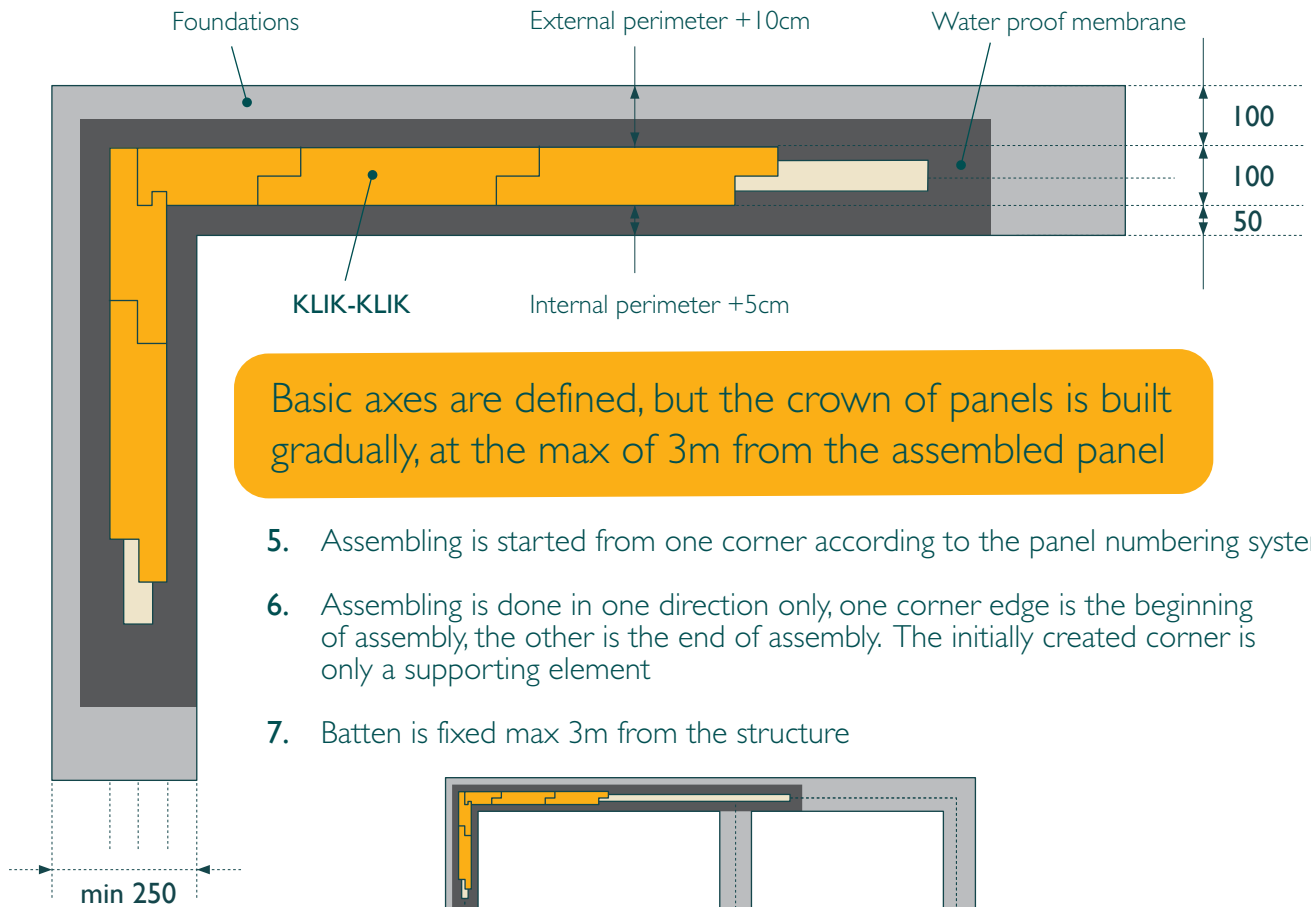

Basic axes are defined, but the crown of panels is built gradually, at the max of 3m from the assembled panel

5. Assembling is started from one corner according to the panel numbering system
6. Assembling is done in one direction only, one corner edge is the beginning of assembly, the other is the end of assembly. The initially created corner is only a supporting element
7. Batten is fixed max 3m from the structure

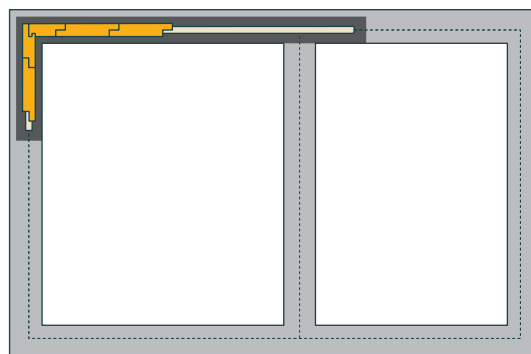

8. The batten is drilled max. 3 m "forward", the drilling is carried out according to pre-set height marks on the axis of the foundation, this is essential if the foundations are not perfectly level
9. The installation of the batten is carried out in parallel with the assembly of the panels
10. Make sure that the batten is at the correct level

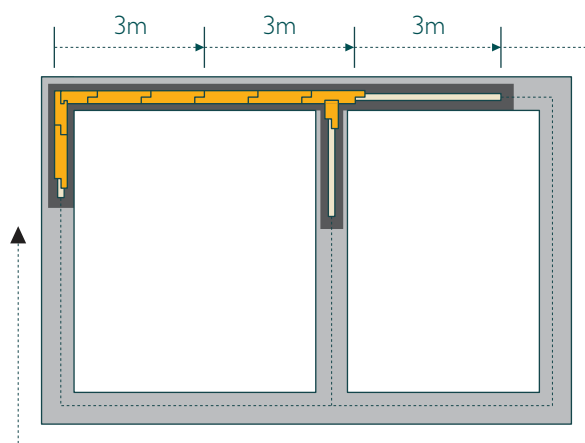

Panel storage

11. Do not store panels in direct sunlight or in the rain
12. The relative wood humidity of each **KLIK-KLIK** panel delivered does not exceed 14%
13. After assembling panels must be covered

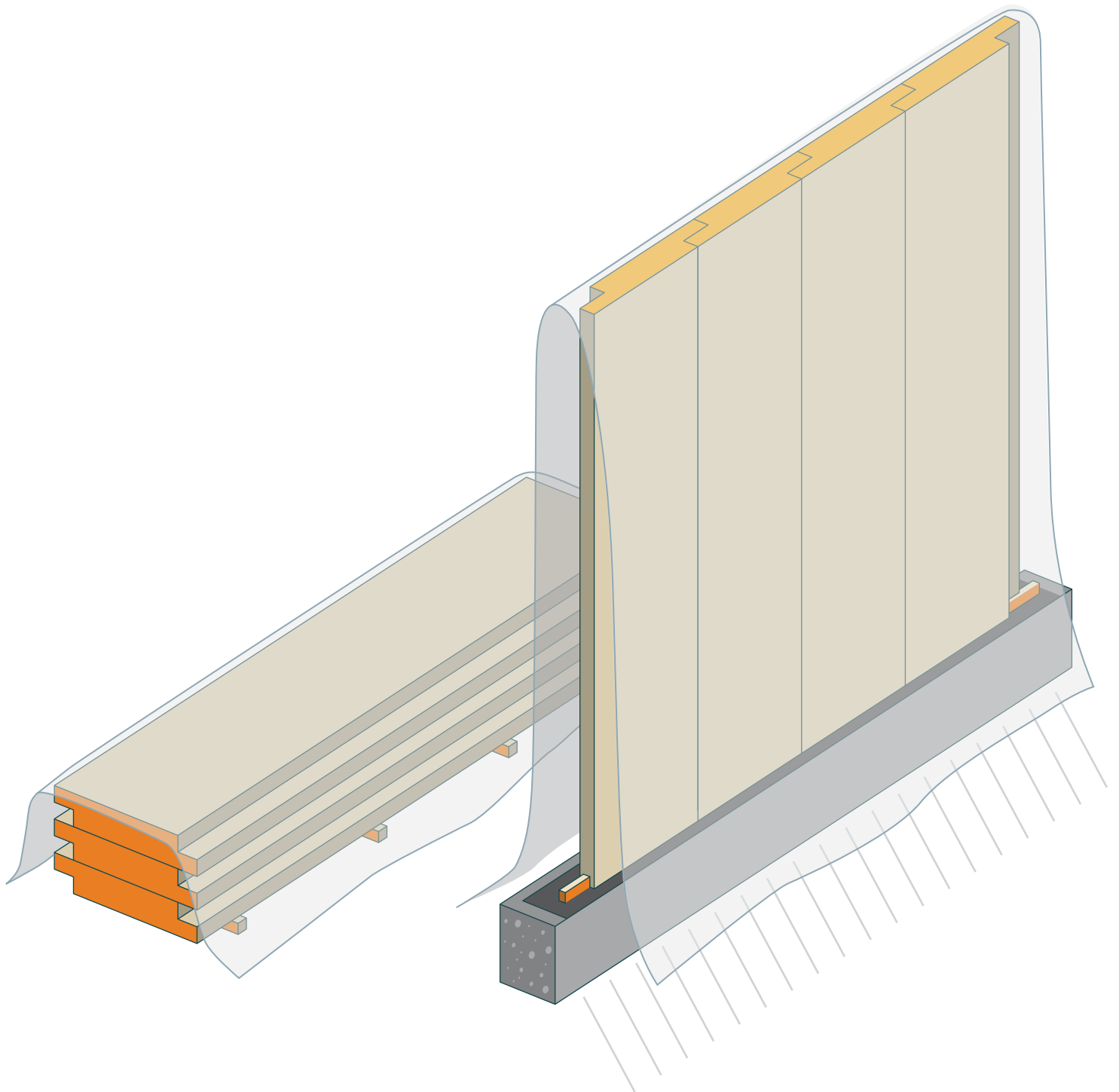

The geometry stability of construction

There is natural expansion and contraction $\pm 3\text{cm}$ on 10m

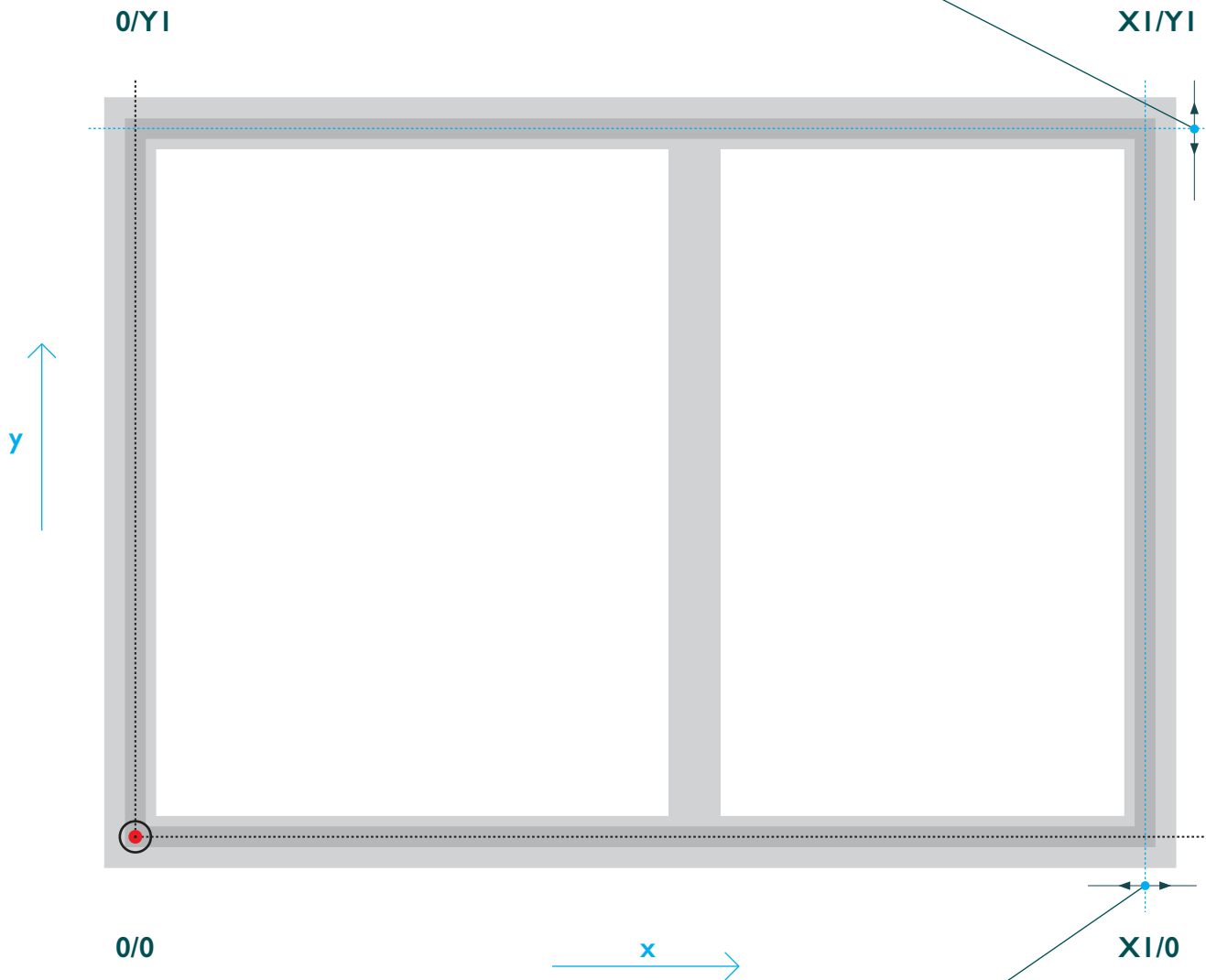

The placement of the wedges

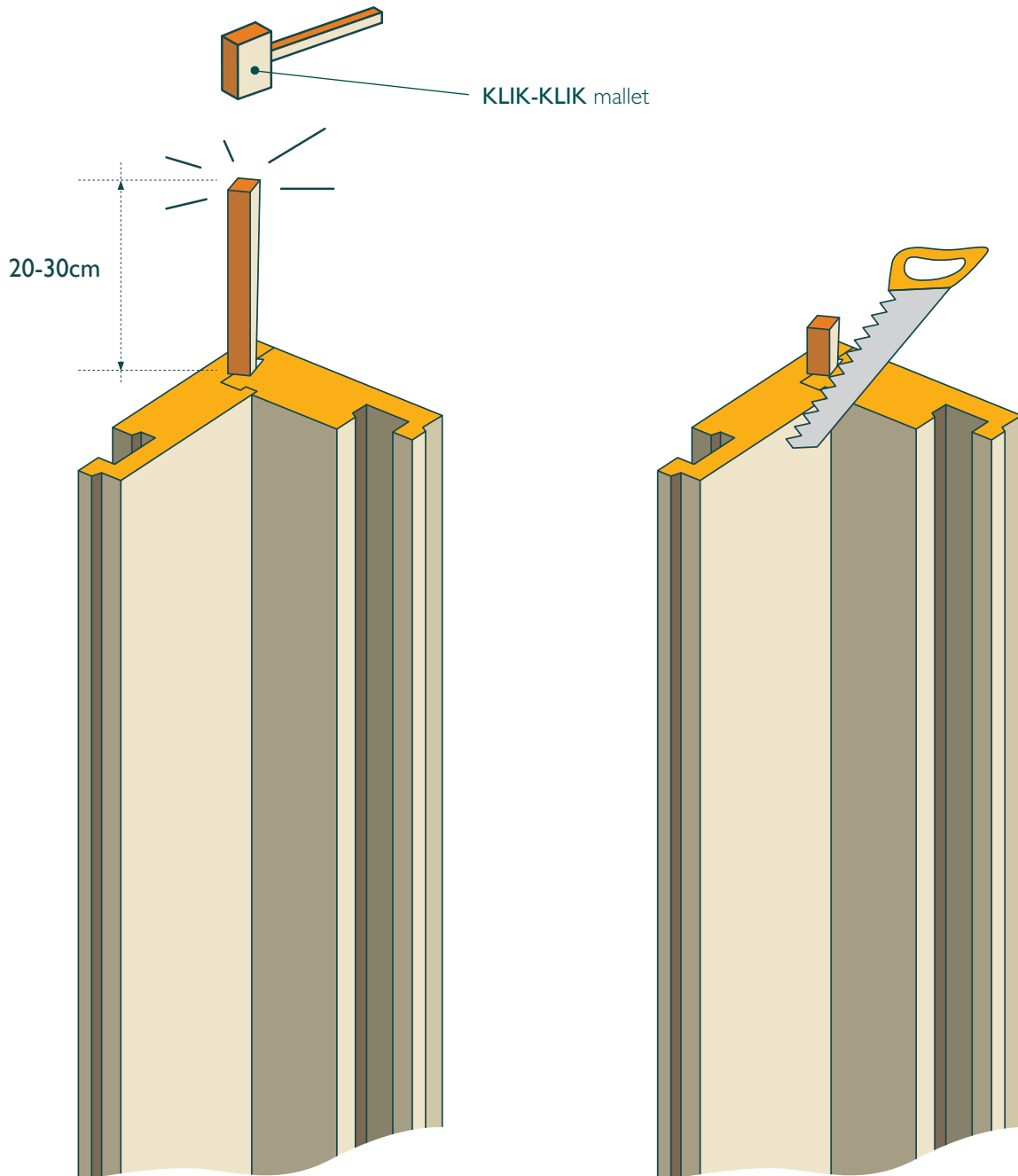

14. Only use a **KLIK-KLIK** mallet or a wooden hammer whose weight does not exceed 1500 grams and total length 400 mm
15. After placing the wedge leave 20-30 cm
16. It is important to note that the wedge may not be driven in completely, do not force it. If this cannot be done with the existing hammer, cut the wedge

The placement of the wedges

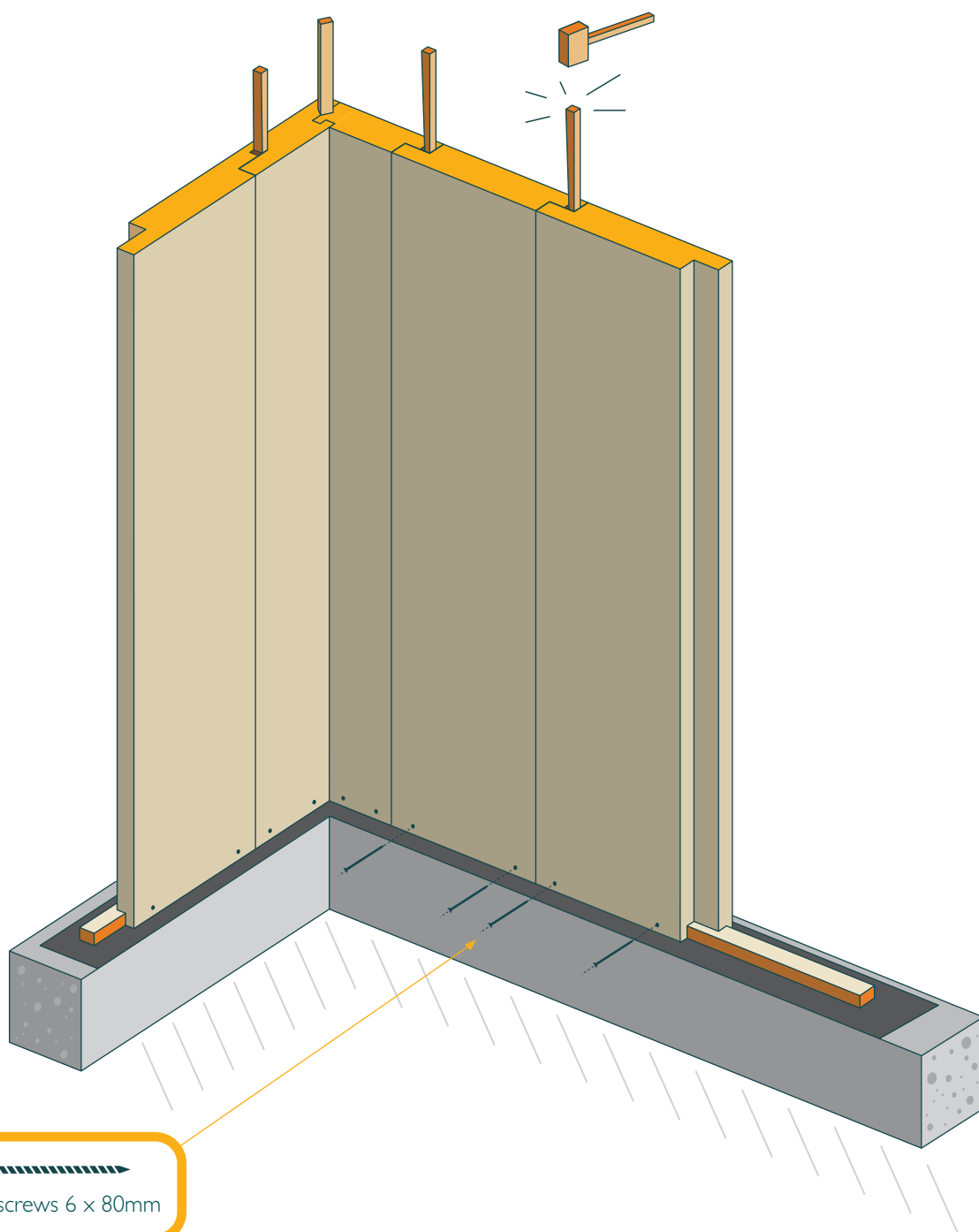

17. When placing **KLIK-KLIK** wedges, tap the wedges soft way and only partially fix the several panels (soft fix) before you go to Nr.18 (Hard fix)
18. Check the geometry and only then fix them to the maximum (hard fix) and if necessary return to Nr.16
19. The **KLIK-KLIK** panels are screwed to the battens at the bottom

!!! Assembly of the structure only according to the engineering project

Work safety

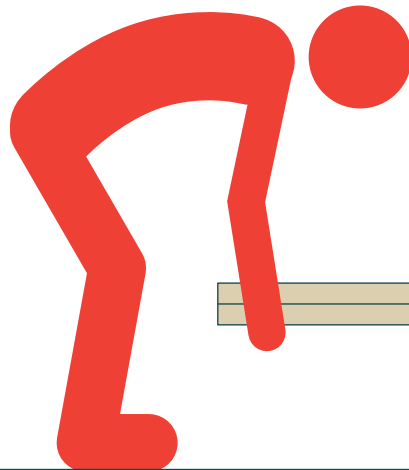

Each **KLIK-KLIK** panel weighs **up to 70 kg**, therefore it is important to observe **work safety**

The **KLIK-KLIK** panel is allowed to be lifted and moved in pairs according to local work safety regulations

Installation of window covering beam

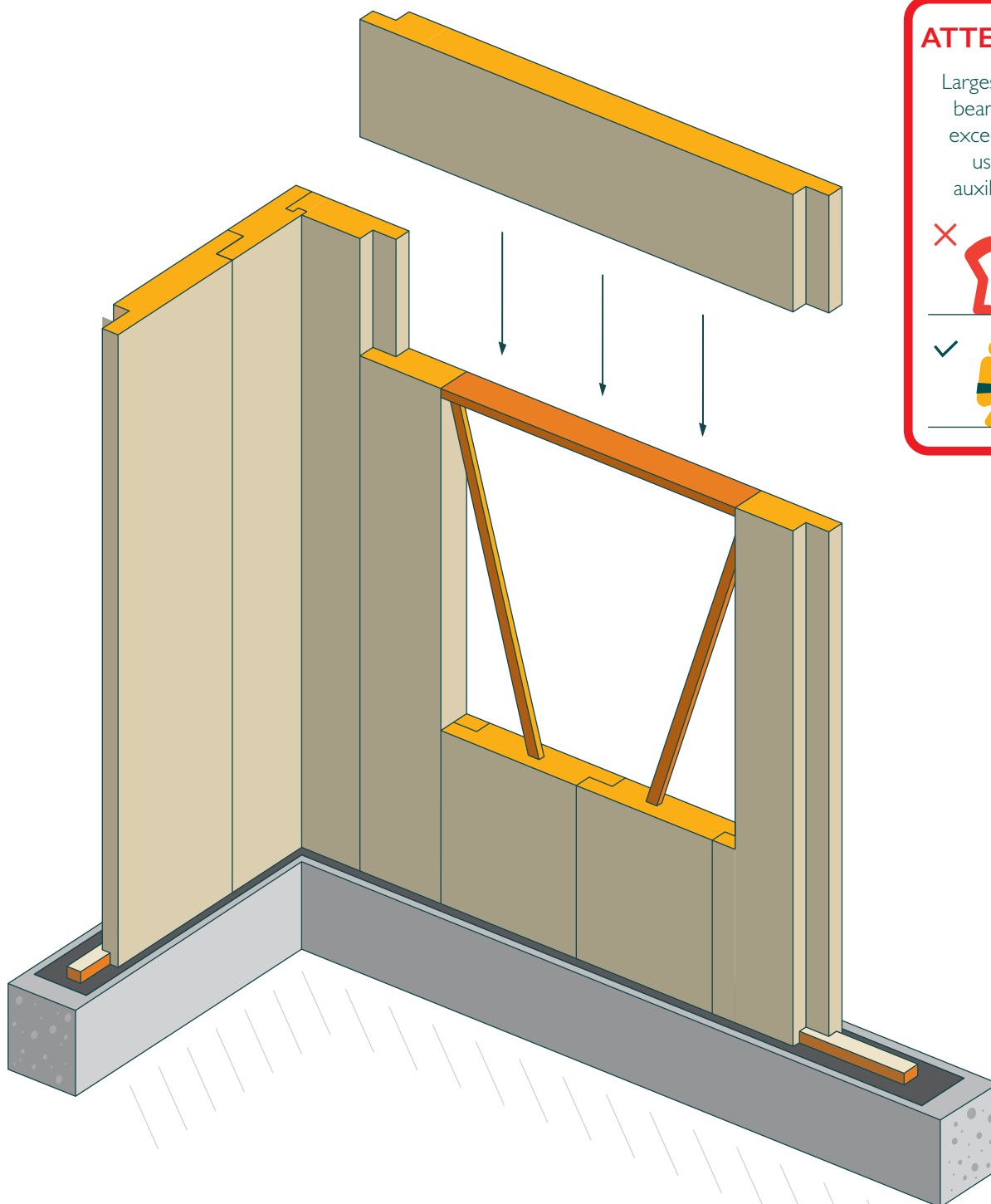

ATTENTION!

Largest covering beam weight exceeds 50 kg, use lifting auxiliary belts

✗ 

✓ 

20. The window covering beam is placed on the side-by-side assembled panels for which the wedges are fixed to the end (hard fix)
21. If necessary, support is provided until wedges are driven in (soft fix)
22. Nominally, the installation is carried out without support and only if necessary, the roof support is carried out

Fixing the roof batten

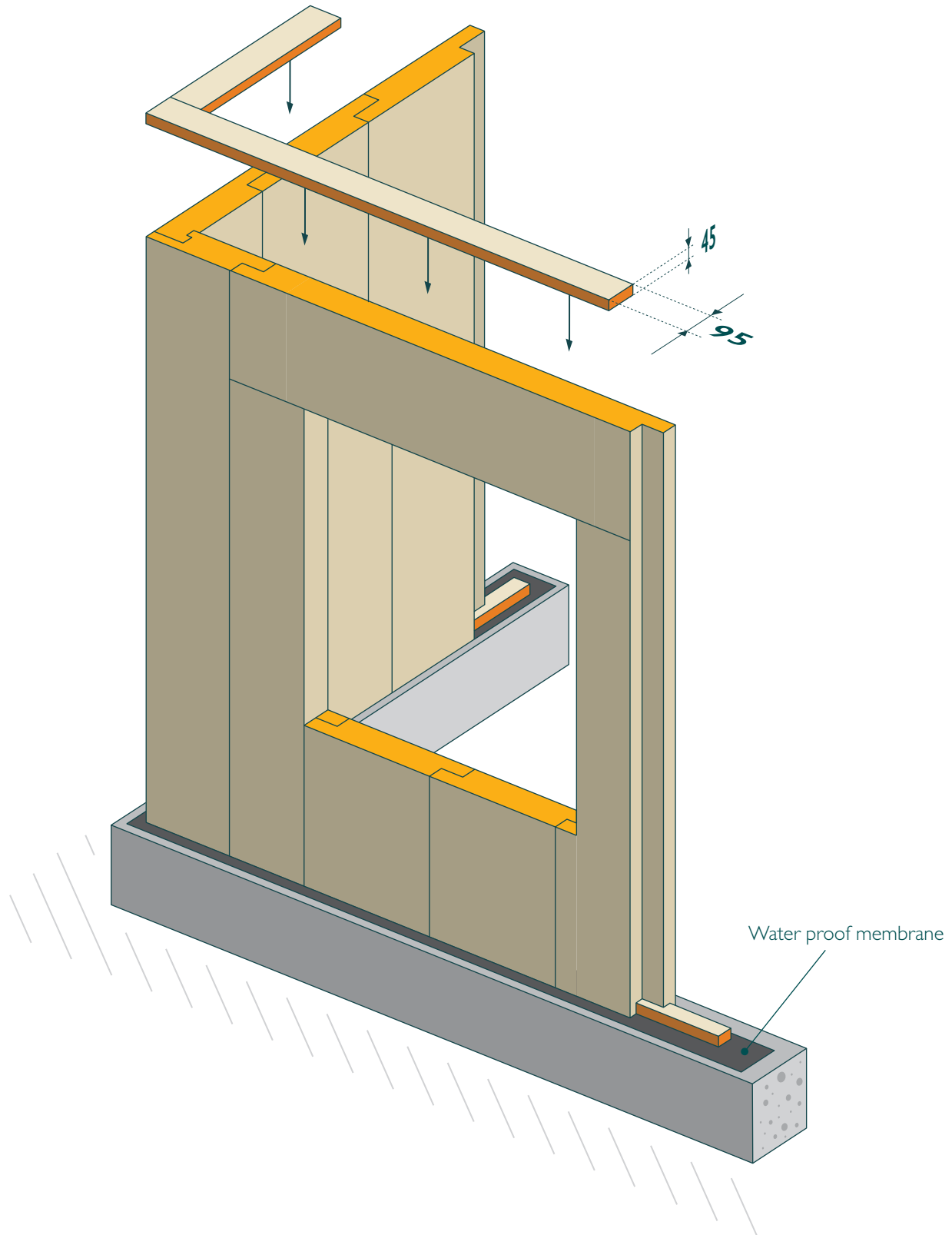

23. Before laying the roof batten, hammer the wedges to the end (hard fix) so that the top plane is smooth

Fixing the roof batten

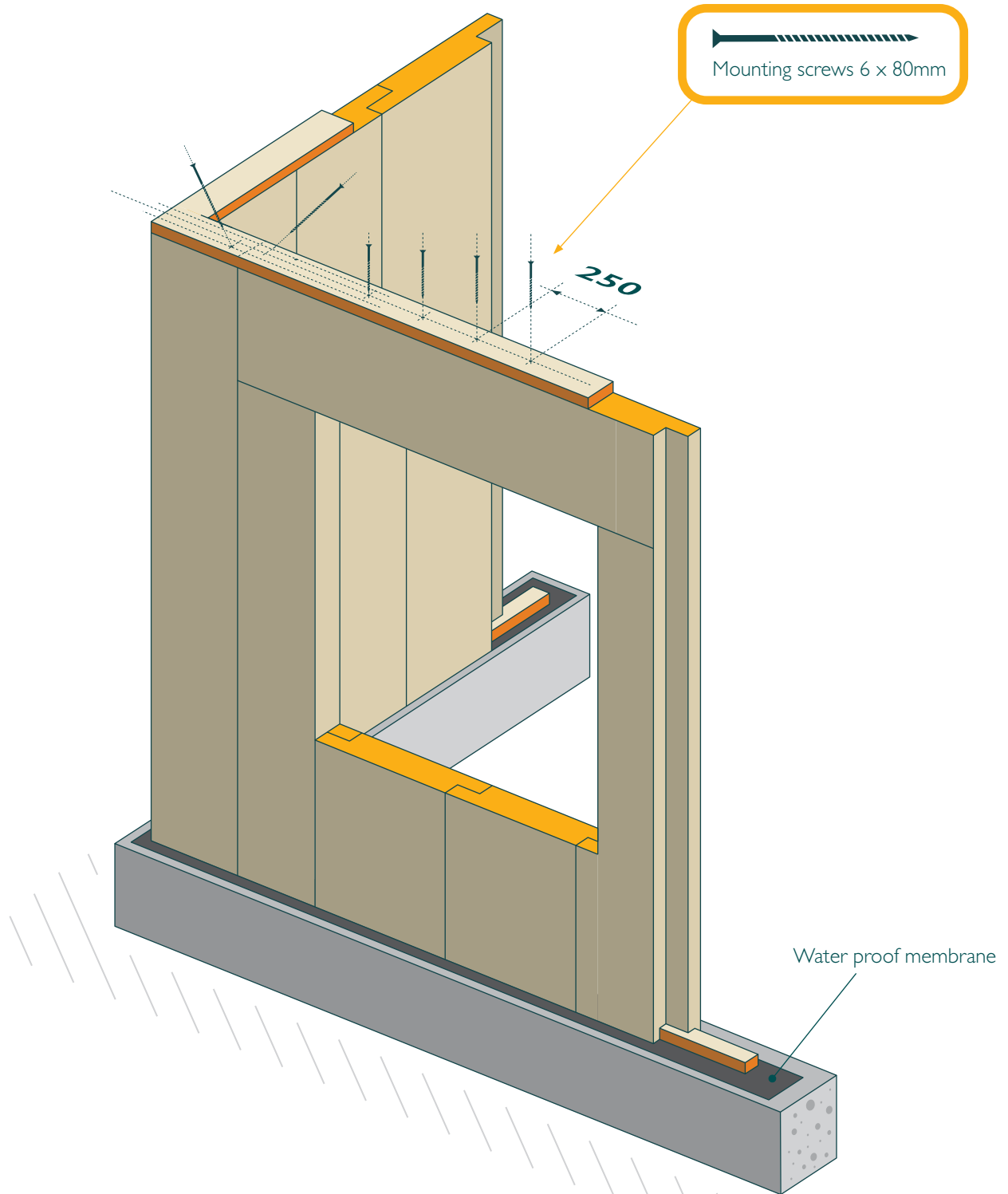

- 24. The roof batten is fixed with screws with a pitch of min 250 mm, or three screws for one panel
- 25. Follow the technical project

Fixing the roof batten

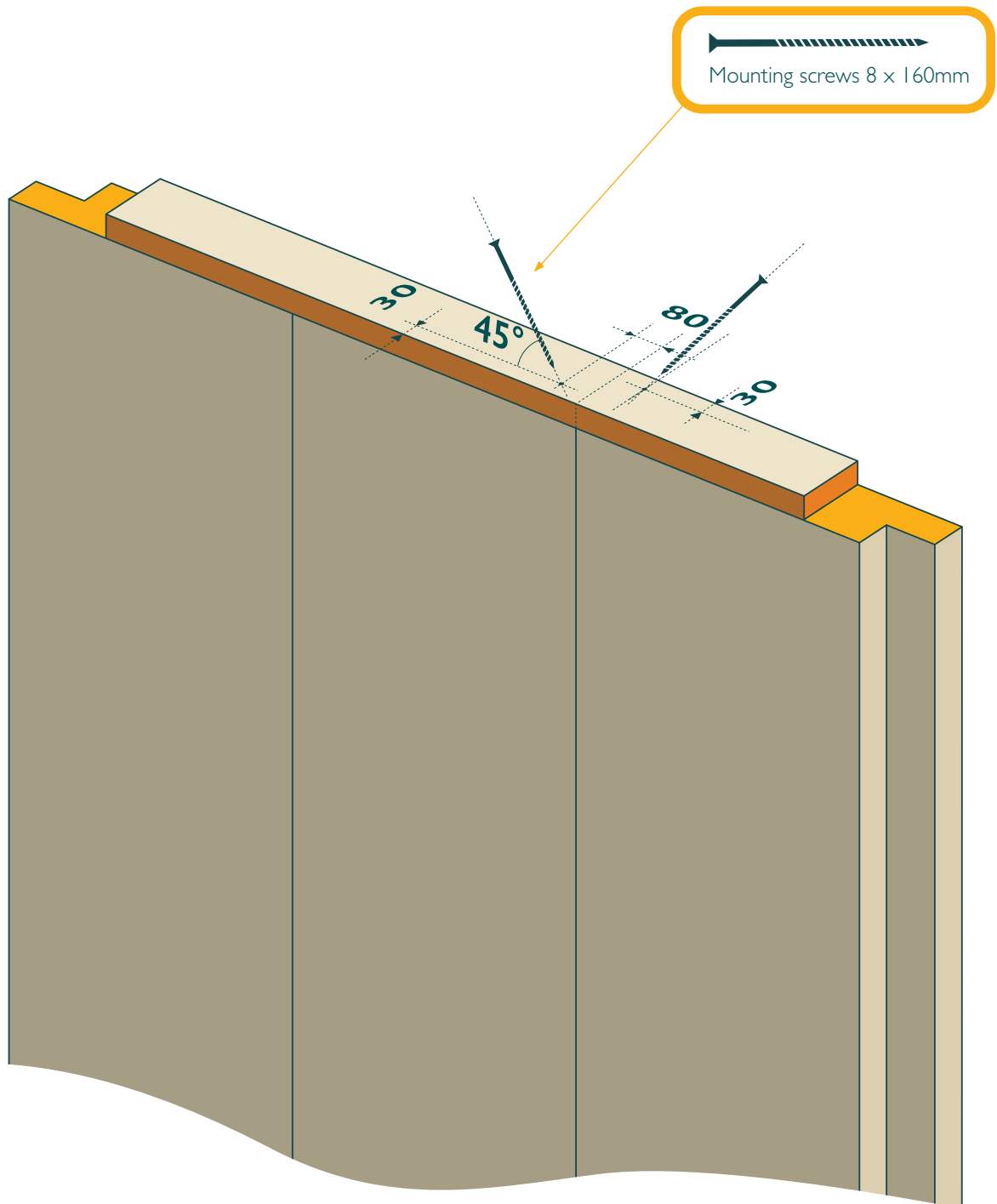

26. Additional screws are used between **KLIK-KLIK** panels with min dimensions 8x160 mm

Strengthening of roof rafters

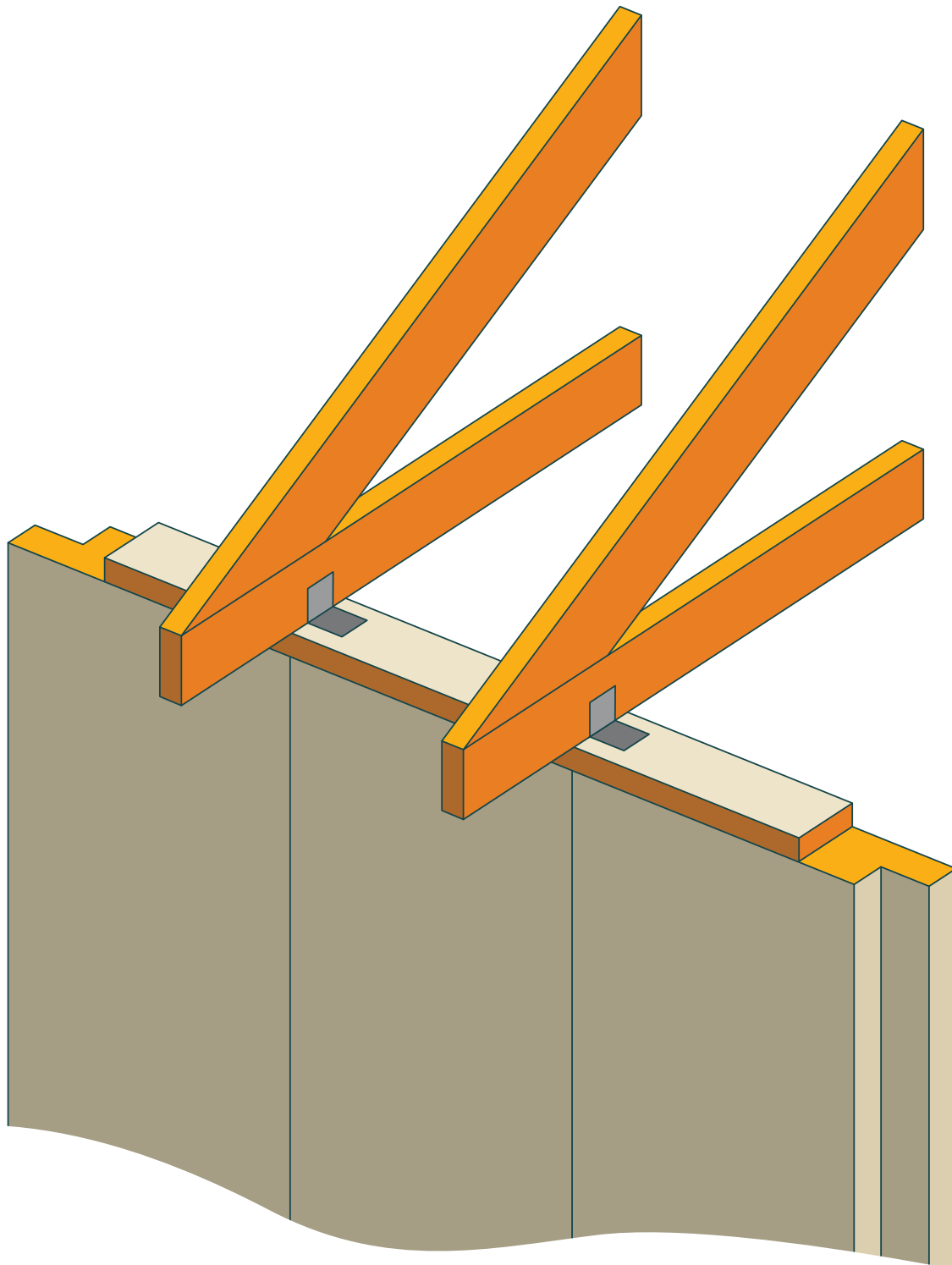

27. The strengthening of the roof trusses is in accordance with the technical project

Electric panel

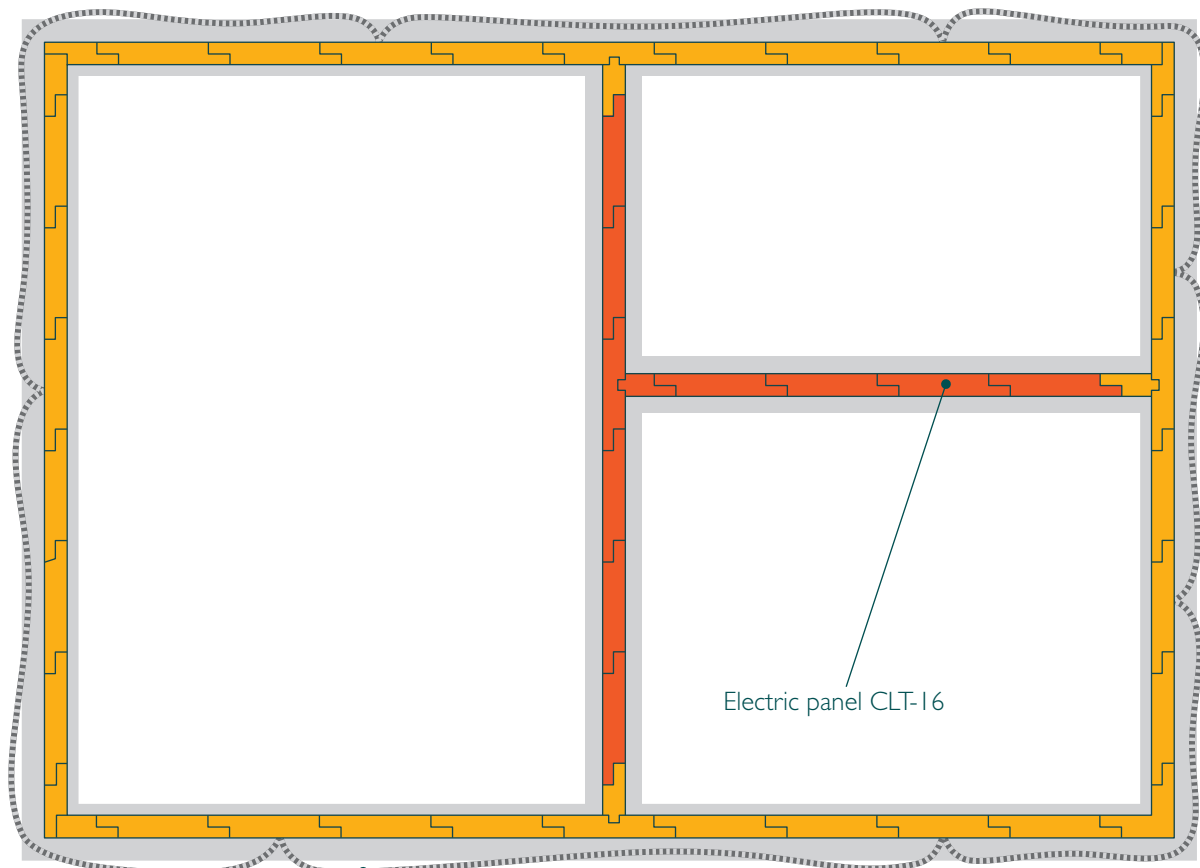

For external walls, the wiring is routed on the outside

- 28. Electric panels - CLT-I6 - to be used only for internal walls!
- 29. For external wall cabling and electricity instalation has to be done **ONLY** from outside

Electric panel

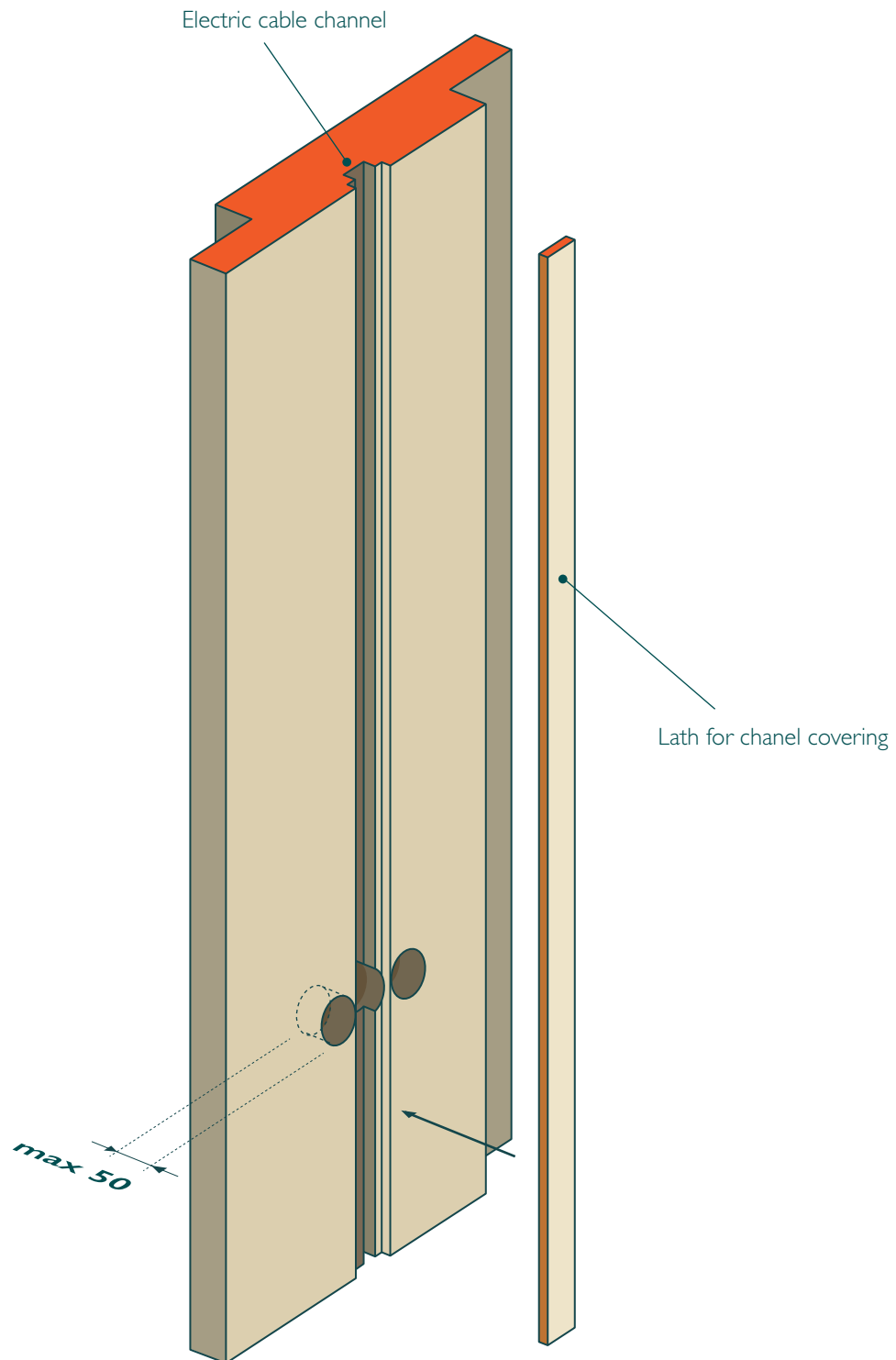

30. A maximum of three rosettes in one panel when installing them on site

Electrical installation for external walls

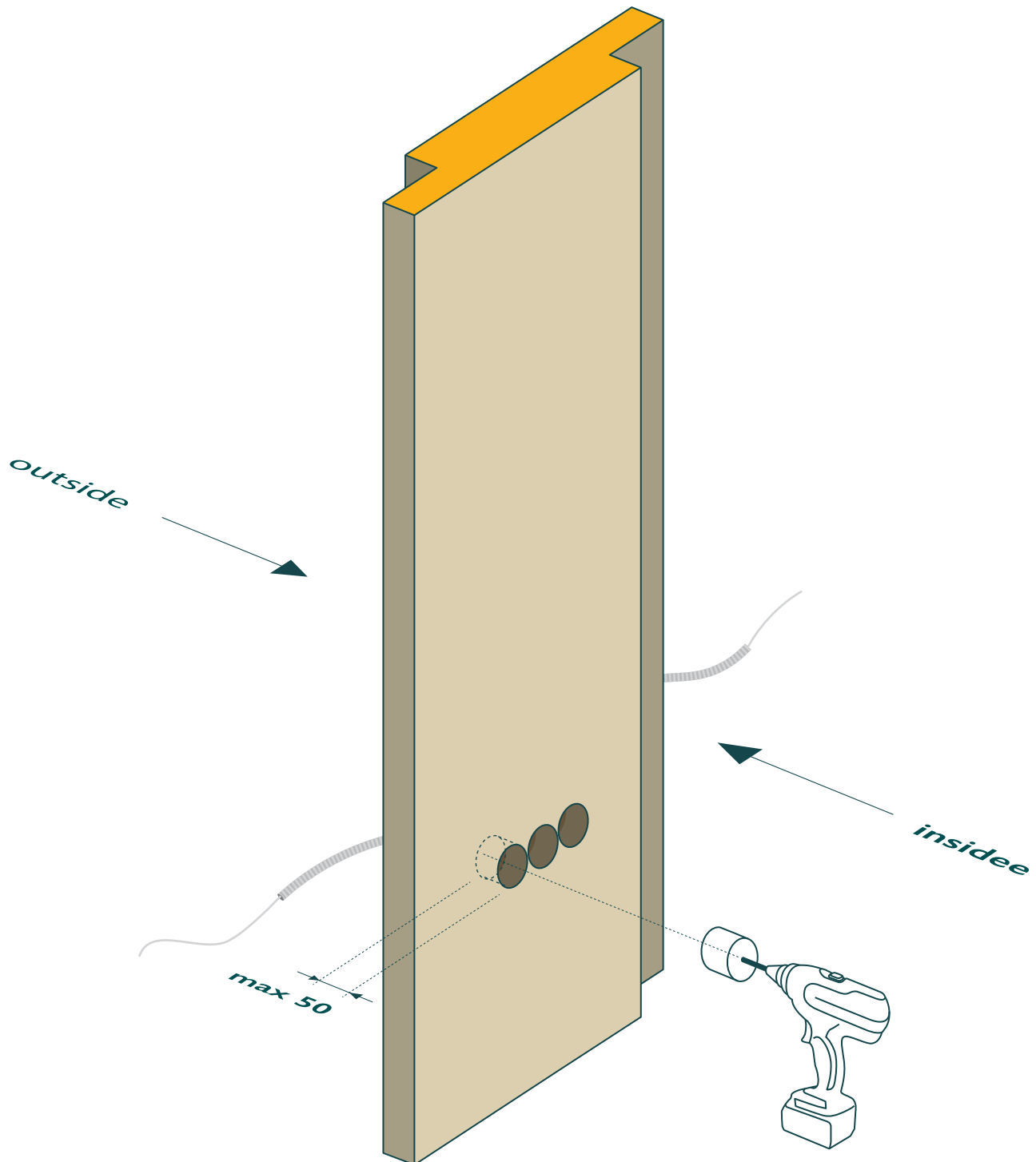

31. For external walls, the electrical wiring is pulled outside and the wires are drilled to the socket from the outside
32. A maximum of three rosettes in one panel when installing them on site

Error correction

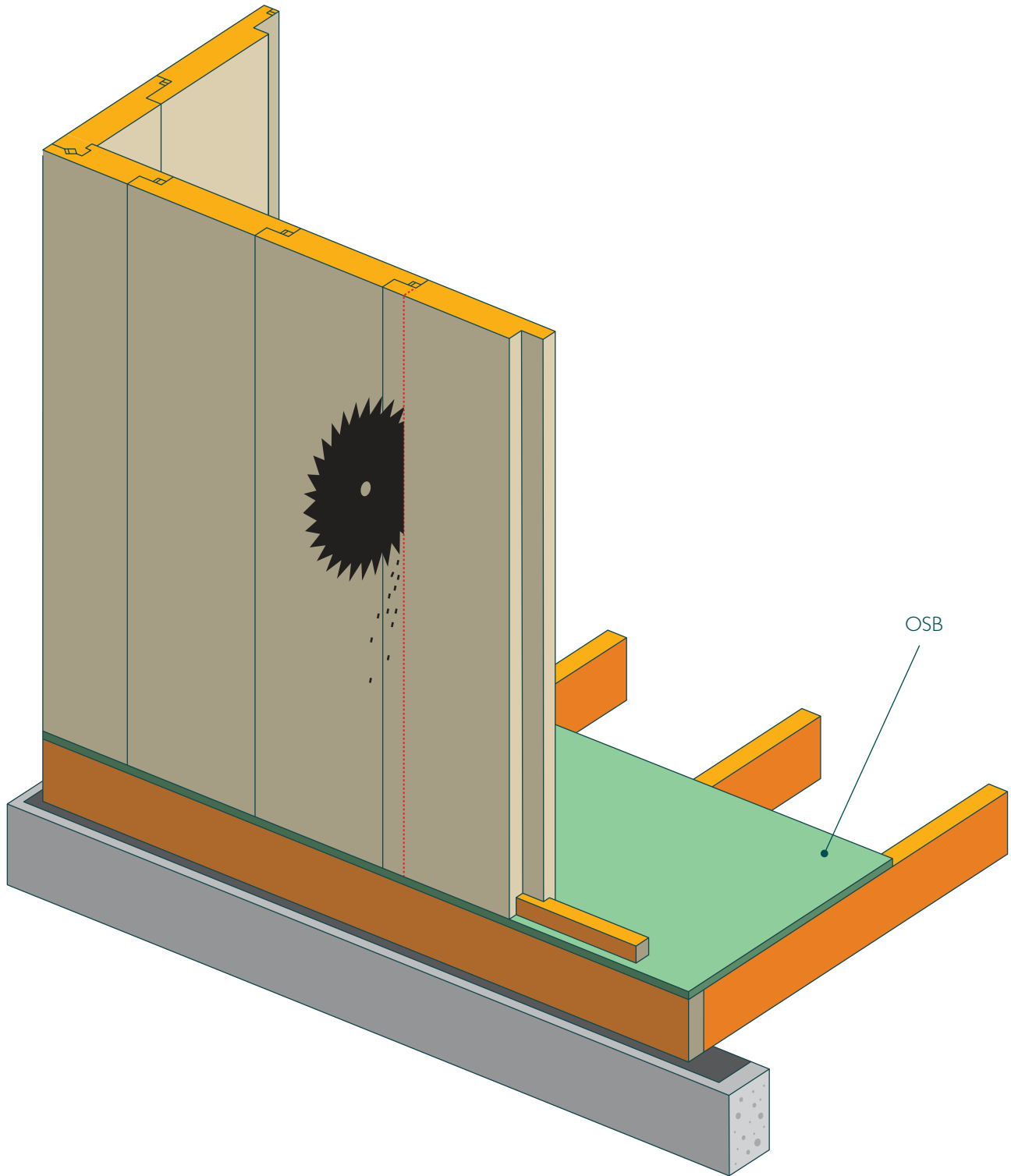

33. In a situation where the panels are mixed up and the wedges are hard fixed (hard fix) and can no longer be removed, we cut the panel so that the wedges can be taken out and the panels can be disassembled. After that, the panel is screwed together with a metal plates and screws

Panel-bearing structure

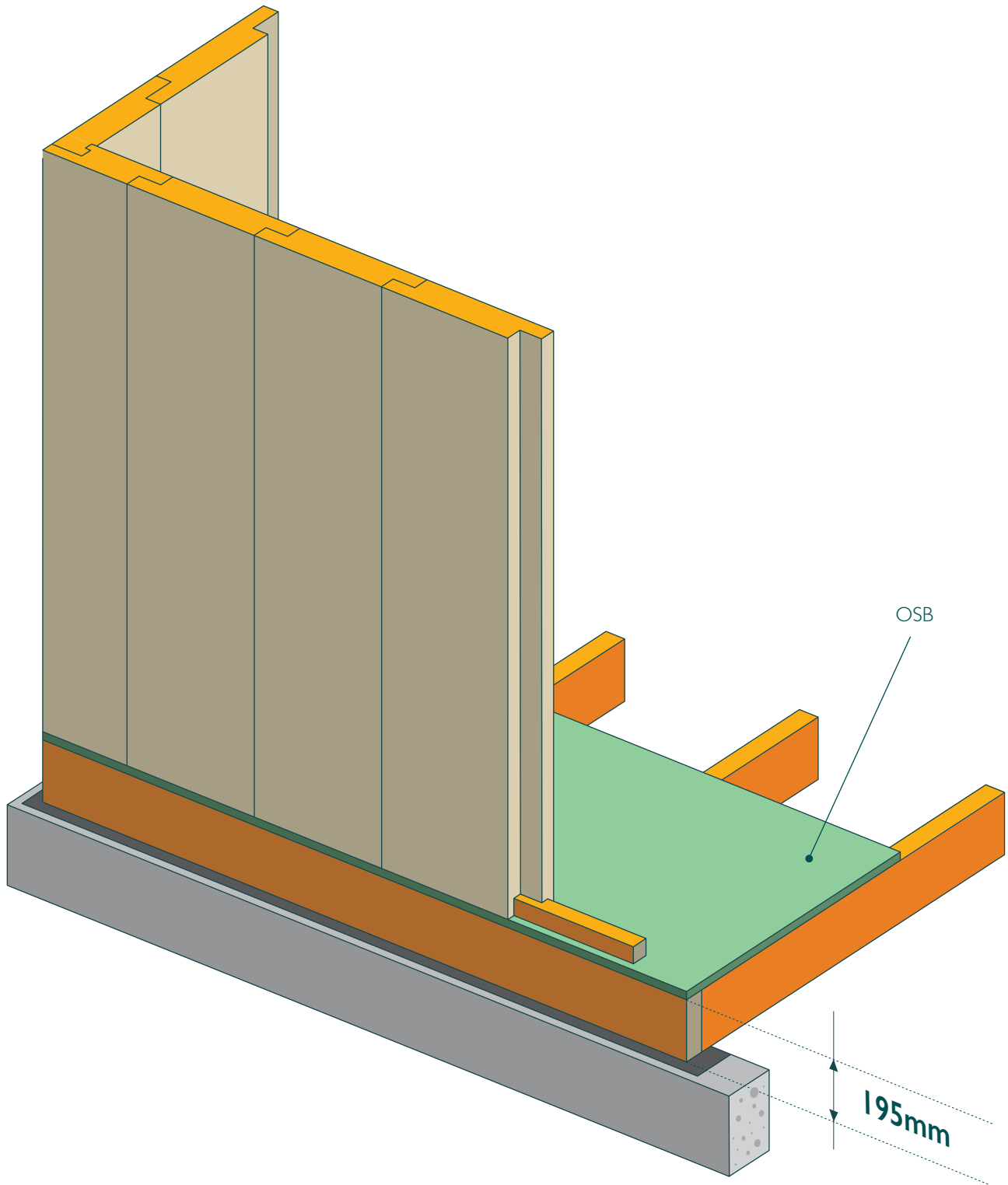

Assembling of internal wall

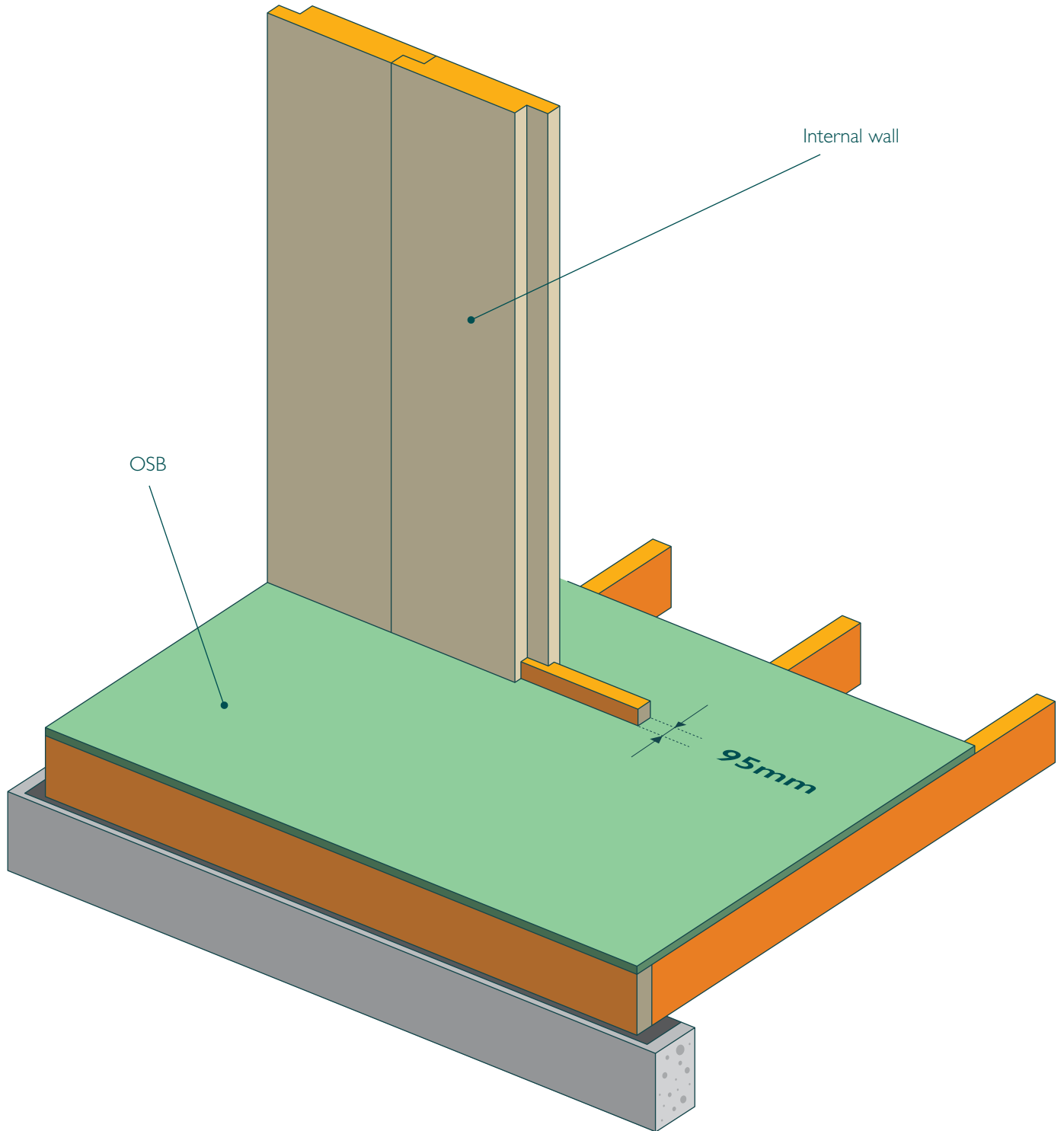

Window assembling opening, type A

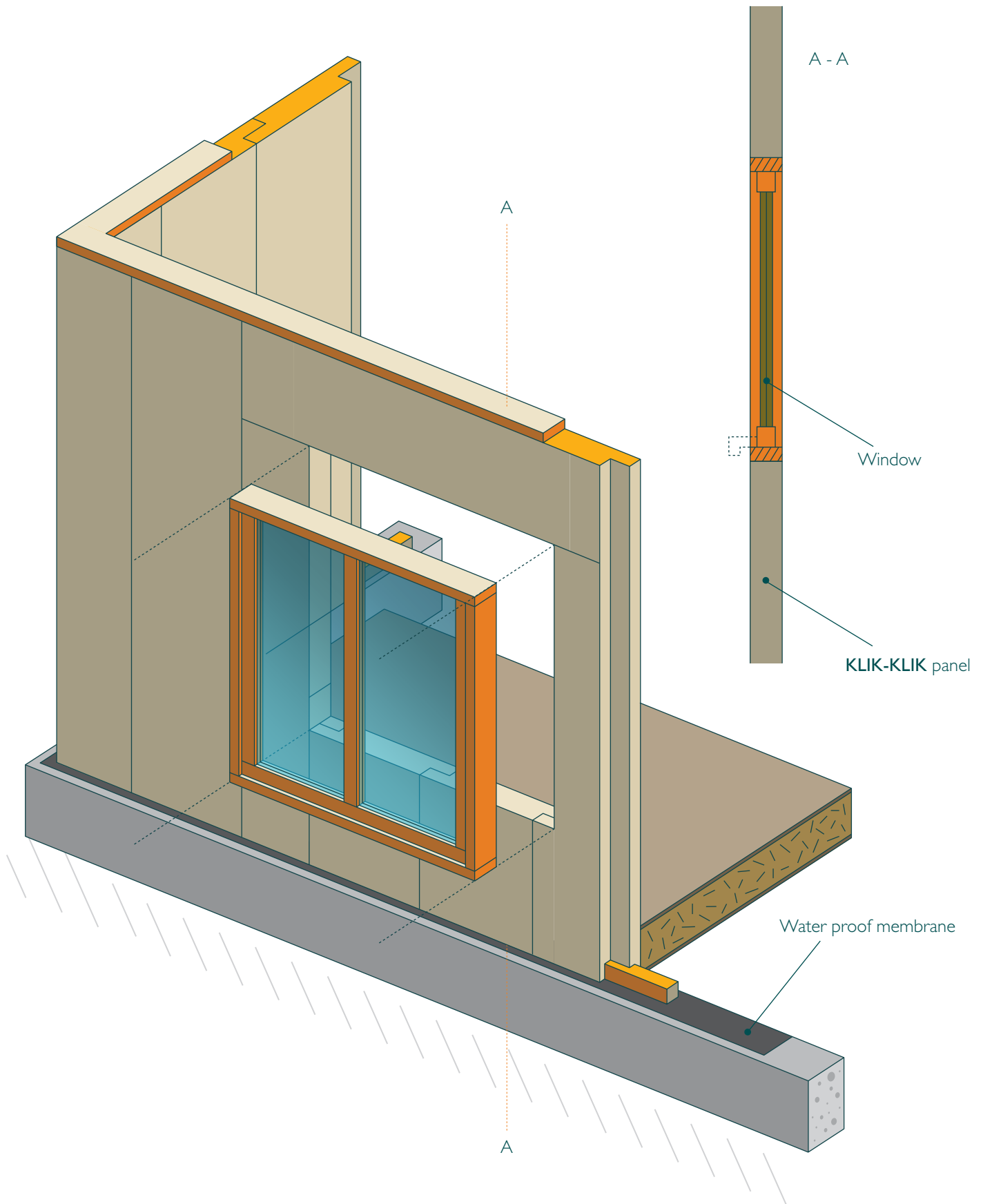

Window assembling opening, type B

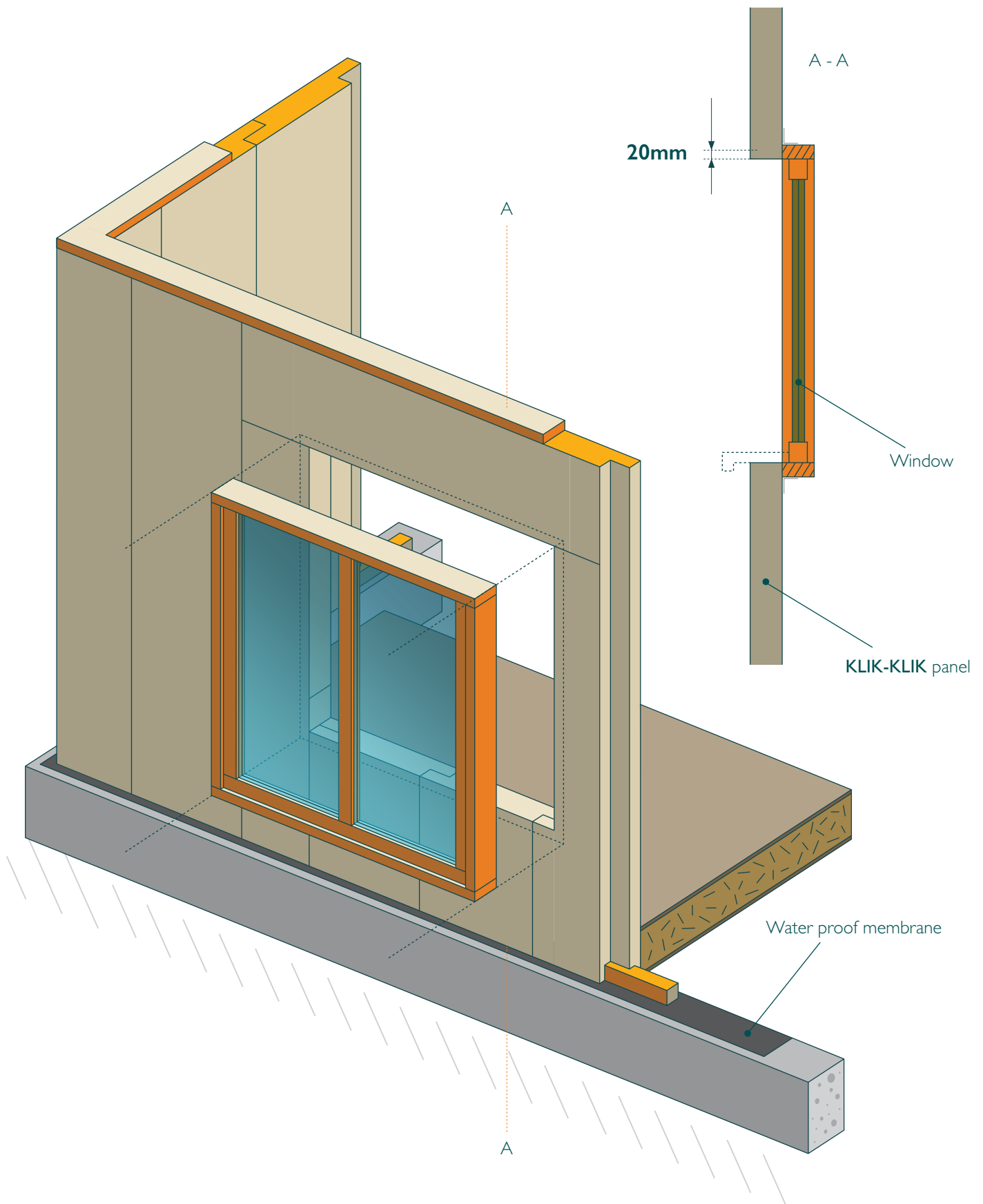

Window and door assembling openings

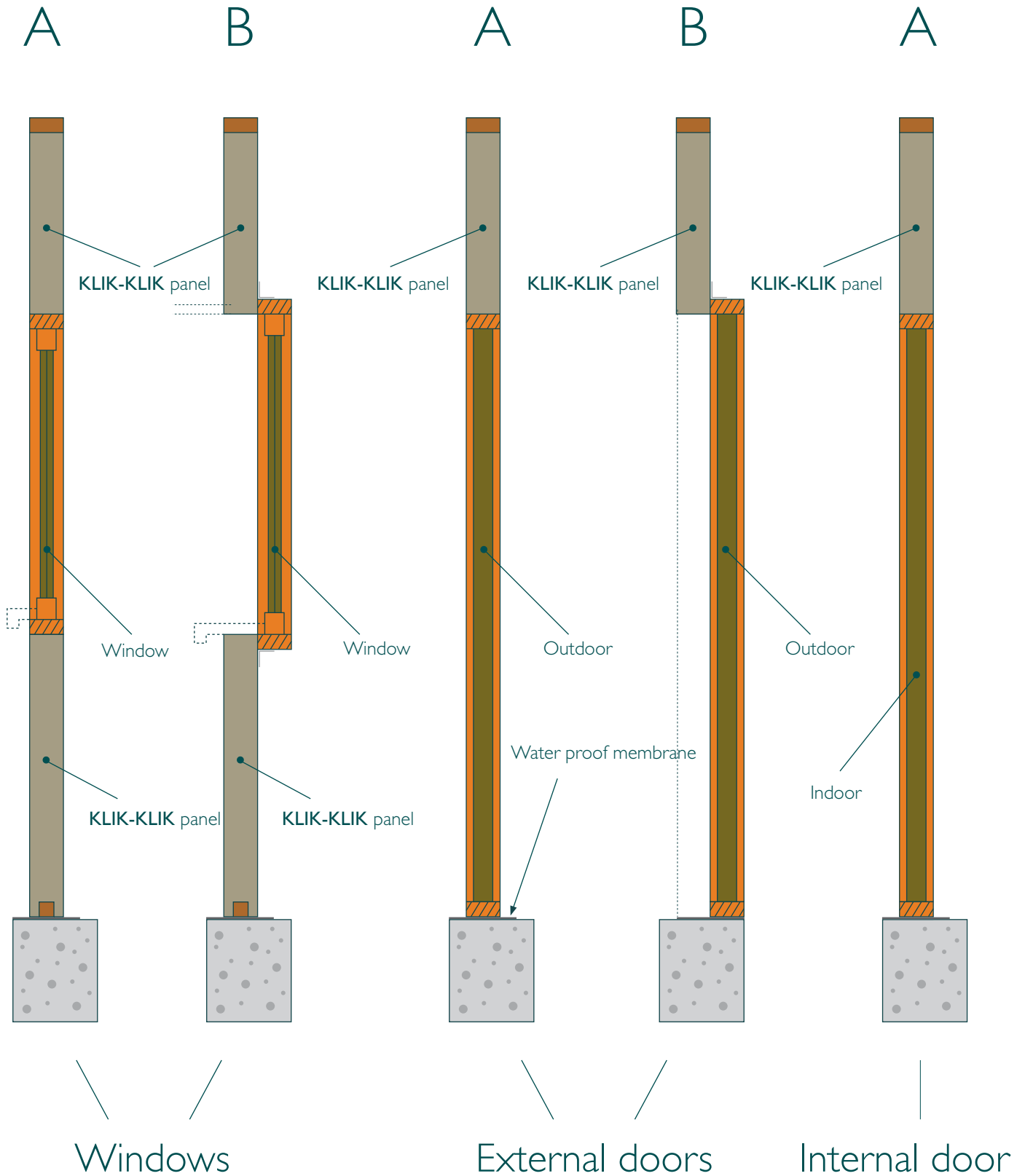

Installed floor

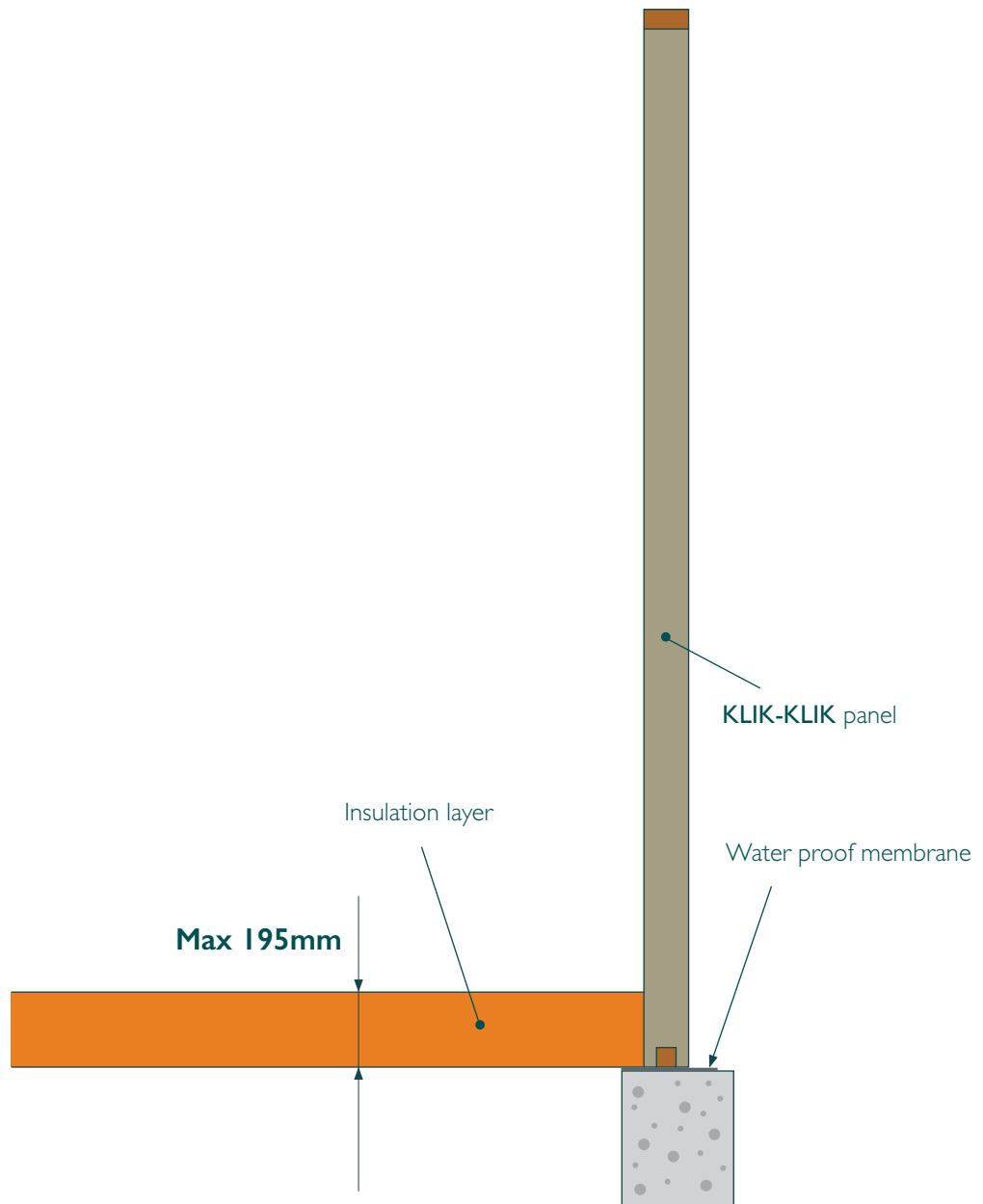

Wooden frame under the CLT

Floor installation:

- Monolithic plane
- Woodenn frame under **KLIK-KLIK**
- Wooden frame in height of **KLIK-KLIK** panel

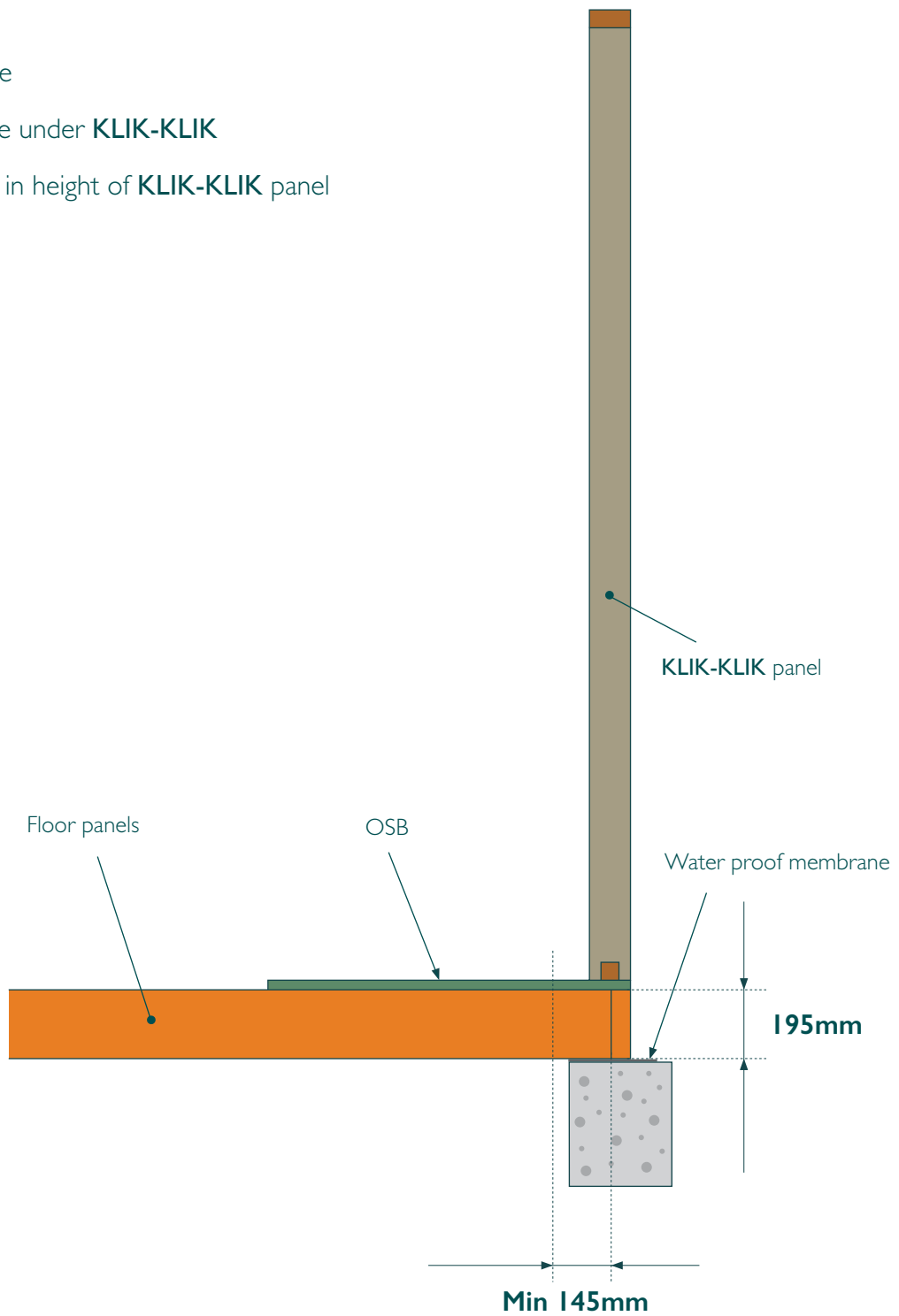



www.cltfactory.com